

**VARDHAMAN COLLEGE OF ENGINEERING**
(AUTONOMOUS)

B. Tech III Semester Regular Examinations, December - 2013

(Regulations: VCE-R11)

DISCRETE MATHEMATICAL STRUCTURES

(Common to Computer Science and Engineering & Information Technology)

Date : 2 December, 2013

Time : 3 Hours

Max. Marks : 75

Answer ONE question from each Unit**All Questions Carry Equal Marks****All parts of the question must be answered in one place only****Unit - 1**

1. a) Define tautology? Show that $q \wedge (p \Rightarrow \neg q) \Rightarrow \neg p$ is tautology without using truth table. 7M
- b) Transform the following formula into CNF $\square (p \rightarrow q) \vee (r \rightarrow p)$ 8M
2. a) Obtain PDNF for $\neg p \vee q$ 7M
- b) Without using truth table prove the following: 8M
 $p \wedge ((\neg p \wedge q) \vee (\neg p \wedge \neg q)) \Leftrightarrow r$

Unit - 2

3. a) Let $A = \{1, 2, 3, 4\}$, $B = \{a, b, c, d\}$, $C = \{x, y, z\}$ and let 7M
 $R = \{(1, a), (2, d), (3, a), (3, b), (3, d)\}$ and $S = \{(b, x), (b, z), (c, y), (d, z)\}$. Give pictorial representation of the relation and find $R \circ S$.
- b) Let $A = \{2, 3, 4, 5\}$ and let $R = \{(2, 3), (3, 3), (4, 5), (5, 1)\}$. Is R symmetric, asymmetric or 8M
antisymmetric?
4. a) Let $A = \{a, b, c, d, e\}$ and the following diagram represents the digraph of the partial 7M
order relation on A. Draw Hasse diagram showing the steps.

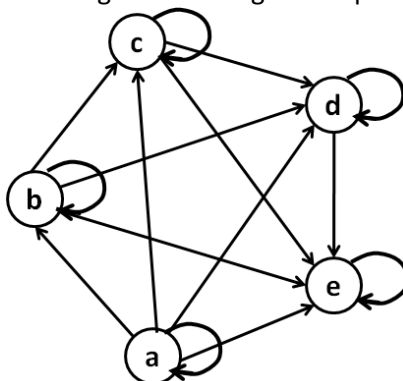

- b) State whether or not each of the relations given below defines a function of $A = \{a, b, c\}$ 8M
into $B = \{1, 2, 3\}$.
 - i. $f = \{(a, 2), (a, 3), (b, 3), (c, 1)\}$
 - ii. $f = \{(a, 2), (b, 3)\}$
 - iii. $f = \{(a, 1), (b, 3), (c, 1)\}$
 - iv. $f = \{(a, 1), (b, 2), (c, 3)\}$

Unit - 3

5. a) Let $(I, +)$ be a semi-group and R is an equivalence relation on I defined by aRb iff $a \equiv b \pmod{3}$. Show that R is congruence relation on I . 7M
- b) Let $\langle L, \leq \rangle$ be a lattice. For any $a, b, c \in L$, Prove the following inequalities, called distributive inequalities, hold : 8M
- i. $a \vee (b \wedge c) \leq (a \vee b) \wedge (a \vee c)$
- ii. $a \wedge (b \vee c) \geq (a \wedge b) \vee (a \wedge c)$
6. a) Determine whether the algebraic system $(Q, +)$ is a group where Q is the set of all rational numbers and $+$ is an addition operation. 7M
- b) Prove that $G = \{1, 2, 3, 4, 5, 6\}$ is a finite abelian group of order 6 under multiplication modulo 7. 8M

Unit - 4

7. a) We are interested in forming 3 letter words ("3-words") using the letters in LITTLEST. For the purposes of the problem, a "word" is any ordered list of letters. 8M
- i. How many words can be made with no repeated letters?
- ii. How many words can be made with unlimited repetition allowed?
- iii. How many words can be made if repeats are allowed but no letter
- iv. Can be used more often than it appears in LITTLEST?
- b) How many positive integers n can we form using the digits 3,4,4,5,5,6,7 if we want n to exceed 5,000,000? 7M
8. a) Find the number of integers between 1 and 10000 that are not divisible by 6,7 or 8. 10M
- b) Find the coefficient of x^3 in $(1+x+2x^2)(1-2x)^5$. 5M

Unit - 5

9. a) Find the generating function for $a_r =$ the number of non-negative integral solutions of $e_1 + e_2 + e_3 + e_4 + e_5 = r$ where $0 \leq e_1 \leq 3, 0 \leq e_2 \leq 3, 2 \leq e_3 \leq 6, 2 \leq e_4 \leq 6, e_5$ is odd and $1 \leq e_5 \leq 9$. 7M
- b) Solve $a_r - 5a_{r-1} + 6a_{r-2} = 0$ where $a_0 = 2$ and $a_1 = 5$ 8M
10. a) Find the coefficient of x^{32} in $(1+x^5+x^9)^{10}$ 7M
- b) Find the coefficient of x^{20} in $(x+x^2+2x^3+x^4)(x^2+x^3+x^4+\dots)^5$ 8M

--	--	--	--	--	--	--	--	--	--



VARDHAMAN COLLEGE OF ENGINEERING
(AUTONOMOUS)

B. Tech III Semester Regular Examinations, December - 2013

(Regulations: VCE-R11)

MATHEMATICS-III

(Common to Electronics and Communication Engineering &
Electrical and Electronics Engineering)

Date : 2 December, 2013

Time : 3 Hours

Max. Marks : 75

Answer ONE question from each Unit

All Questions Carry Equal Marks

All parts of the question must be answered in one place only

Unit - 1

1. a) Prove that $\beta(m, n) = \frac{\Gamma(m)\Gamma(n)}{\Gamma(m+n)}$ 8M
- b) Prove that $\int_0^{\pi/2} \sqrt{\sin \theta} d\theta \times \int_0^{\pi/2} \frac{d\theta}{\sqrt{\sin \theta}} = \pi$ 7M
2. a) Show that $\frac{d}{dx} \{x^n J_n(x)\} = x^n J_{n-1}(x)$ 7M
- b) Express $f(x) = x^4 + 3x^3 - x^2 + 5x - 2$ in terms of Legendre polynomials. 8M

Unit - 2

3. a) Derive Cauchy-Riemann equations in Cartesian form. 7M
- b) Find an analytic function $f(z) = u + iv$, given $u + v = \frac{2 \sin 2x}{e^{2y} + e^{-2y} - 2 \cos 2x}$ 8M
4. a) Verify that $u = \frac{1}{r^2} \cos 2\theta$, $r \neq 0$ is harmonic. Find an analytic function whose real part is u 8M
- b) Separate $\sin^{-1}(\cos \theta + i \sin \theta)$ into real and imaginary parts, where θ is positive acute angle. 7M

Unit - 3

5. a) Evaluate the integral $\int_C |z|^2 dz$, where C is the square having vertices at the origin O (0, 0) and the points P(1, 0), Q(1, 1), R(0, 1) 8M
- b) Find the Taylor's expansion of $f(z) = \frac{2z^3 + 1}{z^2 + z}$ about the point $z=1$ 7M
6. a) If $\varphi(a) = \int_C \frac{2z^2 - z - 2}{z - a} dz$ where C is the circle $|z| = \frac{5}{2}$, evaluate $\varphi(0)$, $\varphi(2)$ and $\varphi(3)$ 7M
- b) Expand $f(z) = \frac{z}{(z+1)(z+2)}$ in Laurent's series about the point $z = -2$ 8M

Unit - 4

7. a) Determine the poles of the function 7M
 $f(z) = \frac{z^2}{(z-1)^2(z+2)}$ and the residue at each pole.
- b) Evaluate $\int_0^{2\pi} \frac{\cos 2\theta d\theta}{1-2a \cos \theta + a^2} (a^2 < 1)$ 8M
8. a) Evaluate $\int_C \frac{z-3dz}{z^2+2z+5}$, where C is the circle (i) $|z|=1$ (ii) $|z+1-i|=2$ using residue 7M
theorem.
- b) Evaluate $\int_{-\infty}^{\infty} \frac{x^2 dx}{(x^2+1)(x^2+4)}$ 8M

Unit - 5

9. a) Show that the transformation $W=Z^2$ transforms the circle $|z-a|=c_1$ to a cardioids or 7M
limaçon.
- b) Find the bilinear transformation that transforms the points $z_1=i, z_2=i, z_3=-1$ into the 8M
points $w_1=1, w_2=0, w_3=\infty$ respectively.
10. a) Define (i) Complete graph (ii) Bipartite graph (iii) Complete bipartite graph. Give 7M
examples. Also prove that a complete graph with n vertices has $\frac{n(n-1)}{2}$ edges.
- b) Explain the DFS Algorithm. Find a spanning tree for the following graph using DFS 8M
algorithm.

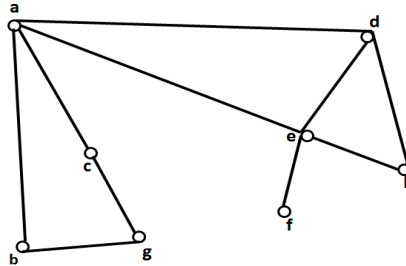

Hall Ticket No

--	--	--	--	--	--	--	--	--	--

Question Paper Code : A1310



VARDHAMAN COLLEGE OF ENGINEERING
(AUTONOMOUS)

B. Tech III Semester Regular Examinations, December - 2013

(Regulations: VCE-R11)

MACHINE DRAWING

(Mechanical Engineering)

Date : 2 December, 2013

Time : 3 Hours

Max. Marks : 75

Answer Two question from Unit-1

Unit-2 is compulsory

All parts of the question must be answered in one place only

Unit - 1

1. Draw the front view and side view of a square headed bolt with a washer and hexagonal nut assembly. 15M
2. Draw the plan and sectional elevation of triple riveted, chain lap joint to join two plates of thickness t . Use snap head rivets. Indicate all the dimensions. 15M
3. Using standard proportions draw the sectional front view and top view of a socket and spigot type cotter joint to join two rods of 20 mm diameter. 15M

Unit - 2

6. Figure 1 shows the details of a machine vice. Assemble the parts and draw:
 i. Sectional front view
 ii. View from the left

45M

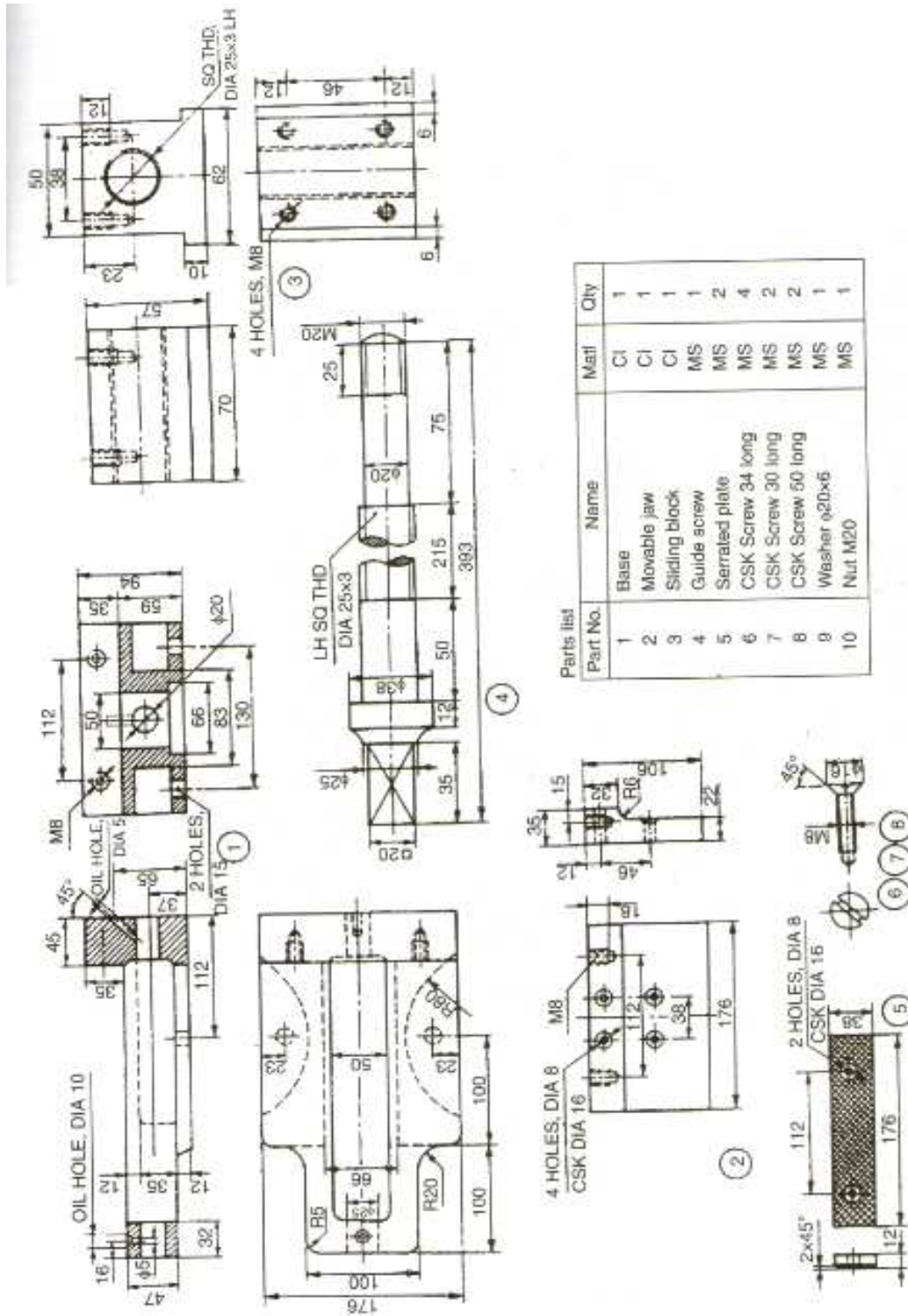

Figure 1: Parts of Machine vice

--	--	--	--	--	--	--	--	--	--



VARDHAMAN COLLEGE OF ENGINEERING
(AUTONOMOUS)

B. Tech III Semester Regular Examinations, December - 2013

(Regulations: VCE-R11)

MATHEMATICS FOR AEROSPACE ENGINEERS

(Aeronautical Engineering)

Date : 2 December, 2013

Time : 3 Hours

Max. Marks : 75

Answer ONE question from each Unit

All Questions Carry Equal Marks

All parts of the question must be answered in one place only

Unit - 1

1. a) Express $\int_0^1 x^m (1-x^n)^p dx$ in terms of the beta function and evaluate $\int_0^1 x^5 (1-x^3)^{10} dx$ 7M
- b) Prove that $\int_0^{\frac{\pi}{2}} \sin^m \theta \cos^n \theta d\theta = \frac{\Gamma\left(\frac{m+1}{2}\right)\Gamma\left(\frac{n+1}{2}\right)}{2\Gamma\left(\frac{m+n+1}{2}\right)}$ 8M
2. a) Prove that $\int_0^1 x J_n(\alpha x) J_n(\beta x) dx = 0$ Where α and β are distinct roots of $J_n(x) = 0$. 8M
- b) Prove that $(n+1)P_{n+1}(x) = (2n+1)xP_n(x) - nP_{n-1}(x)$. 7M

Unit - 2

3. a) For a certain two-dimensional flow, the stream function is $\Psi = -\frac{y}{x^2 + y^2}$ for $(x, y) \neq (0,0)$. Find the velocity potential. 7M
- b) Find the constant 'a' such that $u = \cos ax \cosh y$ is Harmonic. Also write down $f(z)$ 8M
4. a) If $f(z)$ is a regular function of z , prove that $\left(\frac{\partial^2}{\partial x^2} + \frac{\partial^2}{\partial y^2}\right)|f(z)|^2 = 4|f'(z)|^2$. 7M
- b) Determine all the values of $(1+i)^i$. 8M

Unit - 3

5. a) Verify Cauchy's theorem for the integral of z^3 taken over the boundary of the rectangle with vertices $-1, 1, 1+i, -1+i$ 8M
- b) Evaluate $\int_0^{1+i} (x^2 - iy) dz$ along the path $y = x$. 7M
6. a) Evaluate using Cauchy's integral formula $\int_C \frac{z+4}{z^2+2z+5} dz$, where C is the circle $|z+1+i|=2$. 8M
- b) Obtain the expansion of $\frac{1}{(z-1)(z-2)}$ for $0 < |z-1| < 1$ in Laurent' series. 7M

Unit - 4

7. a) Find the poles and residues at each pole for $f(z) = \frac{2z+1}{z^2-z-2}$ 7M
- b) Evaluate $\int_C \frac{z \cos z}{\left(z - \frac{\pi}{2}\right)^3} dz$ where $c : |z-1| = 1$ using Cauchy's residue theorem. 8M
8. a) Show that $\int_0^{\infty} \frac{dx}{1+x^4} = \frac{\pi}{2\sqrt{2}}$. 7M
- b) Show that $\int_0^{2\pi} \frac{d\theta}{\sqrt{2}-\cos\theta} = 2\pi$. 8M

Unit - 5

9. a) Determine the region of the w – plane into which the following regions are mapped by the transformation $w = z^2$. 8M
- i. Region bounded by the first quadrant of z – plane.
- ii. Region bounded by $x = 1, y = 1, x + y = 1$.
- b) Find the bilinear transformation which maps the points $z = 1, -i, -1$ into the points $w = i, 0, -i$ 7M
10. a) Discuss the transformation $w = e^z$. 7M
- b) If $(ds)^2 = (dr)^2 + r^2(d\theta)^2 + r^2 \sin^2 \theta(d\phi)^2$, find the values of $[22, 1]$ and $[13, 3]$ 8M



VARDHAMAN COLLEGE OF ENGINEERING
(AUTONOMOUS)

B. Tech III Semester Regular Examinations, December - 2013

(Regulations: VCE-R11)

SURVEYING-I

(Civil Engineering)

Date : 2 December, 2013

Time : 3 Hours

Max. Marks : 75

Answer ONE question from each Unit

All Questions Carry Equal Marks

All parts of the question must be answered in one place only

Unit – I

1. a) Explain the principle of surveying with the help of sketches. 8M
b) A line was measured by 20 m chain which was accurate before starting day's work. After chaining 900 m the chain was found to be 6 cm too long. After chaining total distance of 1575 m the chain was found to be 14 cms too long. Find the true distance of the line. 7M
2. a) What do you understand by indirect ranging? Explain the method in detail. 7M
b) A rectangular plot of land measures 2 cm X 3 cm on a village map drawn to a scale of 100 m to 1 cm. Calculate its true area on land. If the plot is redrawn on a topo sheet to scale of 1000 m to 1 cm, what will be its area on the topo sheet. 8M

Unit – II

3. a) Enumerate the differences between Surveyor's Compass and Prismatic Compass. 10M
b) The fore bearing of the lines AB, BC, CD, and DE are $45^{\circ}30'$, $120^{\circ}15'$, $200^{\circ}30'$, and $280^{\circ}45'$ respectively. Find the included angles of B, C and D. 5M
4. a) Explain briefly the permanent adjustments of a Prismatic Compass. 7M
b) Explain Quadrant Bearing. Convert: (i) $45^{\circ}30'$ (ii) $110^{\circ}70'$ (iii) $220^{\circ}30'$ (iv) $300^{\circ}72'$ into QB system. 8M

Unit – 3

5. a) With a neat sketch, explain fly leveling. Explain it briefly. 9M
b) Two points A and B are 1530 meter apart. The following Reciprocal levels were taken with one level. 6M

Level at	Readings on A	Readings on B
A	2.165	3.810
B	0.910	2.355

6. a) Calculate the true level difference between A and B.
Explain the following methods of locating Contours in detail: 8 M
i. Squares method
ii. Cross sectioning method
b) What are the uses of Contours? Explain the characteristics of Contours. 7 M

Unit – IV

7. a) Derive an expression to compute the area by Trapezoidal rule 5M
b) The following offsets are taken from a chain line to a fence. Calculate the area enclosed by the chain line, fence and end offsets by Trapezoidal rule 10M

Dist in m	0	20	40	60	80	100	120	140	160
Offsets in m	12.4	12	11.8	8.6	10.9	11.4	17.6	11.6	15.9

8. a) Derive an expression to compute the area by Simpson's rule 5M
b) A railway embankment is 12 m wide. The ground is level in the traverse direction along the centre line. The side slope is 1H:1.5V. The central heights are 3.7m, 2.6m, 4m, 2.8m, 3m and 2.2m at 20 m intervals. Calculate the volume by Prismoidal formula. 10M

Unit –5

9. a) With a neat sketch, explain in detail, the steps to measure the horizontal angle by Repetition method using a Theodolite. 10M
b) An instrument was set up at a Station P and the angle of elevation to a 4 meter vane above the foot of the staff held at Station Q was $09^{\circ}30'$. Taking the horizontal distance between PQ to be 2000 meter, estimate the RL of Q if the RL of the instrument axis is 2650.38 meter. 5M
10. a) Briefly explain the permanent adjustments of a Theodolite. 6M
b) With a neat Sketch, explain Theodolite with its parts. 9M

--	--	--	--	--	--	--	--	--	--



VARDHAMAN COLLEGE OF ENGINEERING
(AUTONOMOUS)

B. Tech III Semester Regular Examinations, December - 2013

(Regulations: VCE-R11)

ELEMENTS OF ELECTRICAL ENGINEERING

(Common to Computer Science and Engineering & Information Technology)

Date : 4 December, 2013

Time : 3 Hours

Max. Marks : 75

Answer ONE question from each Unit

All Questions Carry Equal Marks

All parts of the question must be answered in one place only

Unit - 1

1. a) State and Explain Reciprocity theorem. 7M
- b) A star connected load has an impedance of $(3+j4)$ ohm in each phase and is connected across a balanced three phase delta connected AC generator having line voltage of 120 V. Obtain the line current of both the load and AC generator. 8M
2. a) Determine Norton's equivalent circuit at terminals AB for the Circuit shown in fig.1. 7M

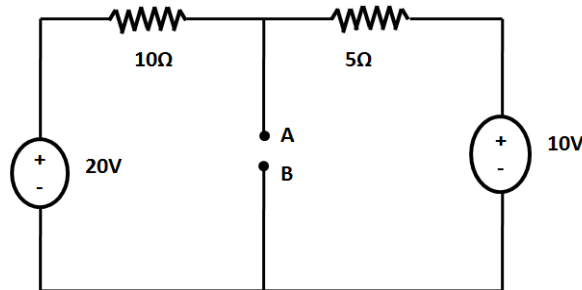

fig.1

- b) Compare single-phase and three-phase supply systems. Deduce the relationship between the phase and line voltages of a 3-phase star-connected system. 8M

Unit - 2

3. a) With neat sketch, explain the working principle of DC generator. 7M
- b) A shunt motor, fed from a 400 V direct current supply, takes an armature current of 100 A when running at 800 RPM. If the total torque developed remains same, find the speed at which the motor will run if the flux is increased to 120% of its original value and a resistance of 0.8Ω is connected in series with the armature. The armature resistance is 0.2Ω . 8M
4. a) Briefly discuss about the various types of DC generators. 8M
- b) Determine the value of torque in N-M, established by the armature of a 4-pole DC motor having 774 conductors, wave wound, having a flux of 24 mWb per pole when the total armature current is 50 Amperes. 7M

Unit - 3

5. a) A 600KVA, single phase transformer has an efficiency of 92% both at full load and half load at unity power factor. Determine its efficiency at 60% of full load at 0.8 power factor lag. 10M
- b) Draw the equivalent circuit of a transformer. 5M
6. a) Explain the various losses in a transformer. 5M
- b) A 20KVA, 440/220V, single phase, 50Hz transformer has iron loss of 324W. The copper loss is found to be 100W when delivering half full load current. Determine the efficiency when delivering a full load current of 0.8p.f lagging. 10M

Cont...2

Unit - 4

7. a) Explain the star delta starting method of an induction motor. 7M
b) A 3 phase, 8 pole 60Hz, induction motor has a rotor emf of 10V induced when the rotor is at stand still. Calculate the frequency of the induced emf, when the rotor rotates at 864 rmp. 8M
8. a) Explain the working principle of a stepper motor. 5M
b) Explain a typical slip-torque curve of a 3 phase induction motor. A 6 pole, 50Hz squirrel cage induction motor runs on no load at a shaft speed of 970rpm. Calculate the percentage slip and the frequency of induced current in the rotor. 10M

Unit - 5

9. a) Derive the emf equation of an alternator. 7M
b) Find the synchronous impedance and reactance of a single phase alternator in which a given field current produces an armature current of 200A on short circuit and a generated emf of 50V on open circuit. The armature resistance is 0.1Ω . To what induced voltage must the alternator be excited if it is to deliver a load of 100A at a power factor of 0.8 lagging with a terminal voltage of 200V. 8M
10. a) Explain the working principle of a synchronous motor. 6M
b) A 3 phase, 16 pole alternator has a star connected winding with 144 slots and 10 conduction per slot. The flux per pole is 0.03Wb sinusoidally distributed and the speed is 375rpm. Find the frequency, phase and line emfs. Assume a winding factor of 0.96. 9M



VARDHAMAN COLLEGE OF ENGINEERING
(AUTONOMOUS)

B. Tech III Semester Regular Examinations, December - 2013
(Regulations: VCE-R11)

PRINCIPLES OF ELECTRICAL ENGINEERING
(Electronics and Communication Engineering)

Date : 4 December, 2013

Time : 3 Hours

Max. Marks : 75

Answer ONE question from each Unit

All Questions Carry Equal Marks

All parts of the question must be answered in one place only

Unit - 1

1. a) State and explain Thevenin's theorem. 8M
 b) Find 'v' by Superposition theorem for the circuit shown in fig.1. 7M

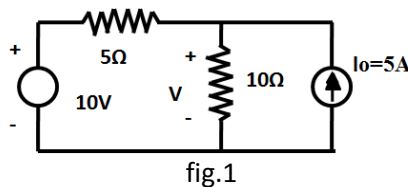

2. a) State and explain Tellegen's Theorem. 7M
 b) What should be the value of R such that maximum power transfer can take place from the rest of the network to R in fig.2? Obtain the amount of this power. 8M

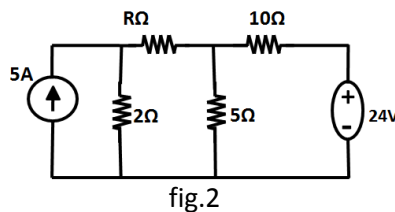

Unit - 2

3. a) For the circuit shown in fig.3a, Find the current equation when the switch is changed from position 1 to position 2 at t=0sec. 8M

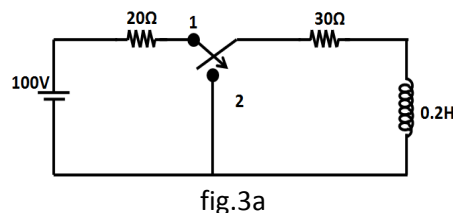

- b) The series R-L circuit fed from AC source is shown in below fig.3b. Load components are R=150 Ω and L=0.5 H. The switch is closed when $\Phi=30^\circ$. Determine the resultant current when voltage $V=50 \cos(100t+\Phi)$ is applied to the circuit at $\Phi=30^\circ$. 7M

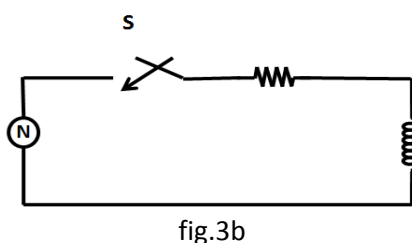

4. a) Show how R,L and C behaves under switching (transient) conditions , i.e at $t=0+$ and at $t=$ infinity. 6M
- b) In the circuit shown in fig.4 below switch k is changed from position 1 to 2 at $t=0$, steady state having been reached before switching. Find $i(0+)$, di/dt and d^2i/dt^2 at $t=0+$. 9M

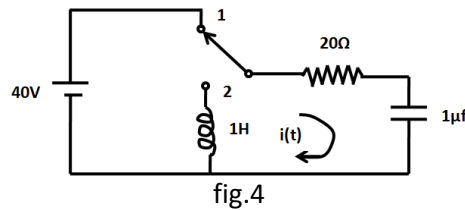

Unit - 3

5. a) A 4-pole, lap wound, dc shunt generator has a useful flux per pole of 0.07 Wb. The armature winding consists of 220 turns each of 0.004 Ω resistance. Calculate the terminal voltage when running at 900 RPM, if the armature current is 50 A. 8M
- b) What are the advantages and disadvantages of Rheostatic control method of DC motor? 7M
What are the advantages of field control method of DC motor?
6. a) How do you classify different types of DC generators? Draw their corresponding circuit diagrams. 7M
- b) A 25 kW, 250 V, DC shunt generator has armature and field resistances of 0.06 Ω and 100 Ω respectively. Determine the total armature power developed when working
- i. As a generator delivering 25 kW output and
 - ii. As a motor taking 25 kW input

Unit - 4

7. a) List the losses in a transformer which are independent of load. How are they reduced? 4M
- b) The following readings are obtained for OC and SC tests on a 8kVA, 400/120 V, 50Hz transformer. 11M
OC test on LV side: 120 V, 4A, 75w
SC test on HV side: 9.5V, 20A, 110w.
Calculate
- i. The equivalent circuit constants referred to high voltage side.
 - ii. The efficiency at half load and 0.8 power factor lagging
8. a) Define voltage regulation. Also give reason why core loss is neglected in short circuit test and copper loss in short circuit test. 3M
- b) Explain the principle of operation of the transformer on load with RL load. Draw the vector diagram. A single phase 440/110V transformer takes a no – load current of 4A at 0.2 pf. If the secondary supplies a current of 100A at a pf of 0.8 lagging, determine (i) the current taken by the primary winding, (ii) magnetizing reactance and resistance representing core loss. 12M

Unit - 5

9. a) With the help of a neat circuit explain different types of induction motor. 6M
- b) Explain how a 3 phase induction motor starts rotating when a balanced 3 phase voltages are applied to the stator windings. 6M
- c) What will be the frequency of rotor currents under running conditions 3M
10. a) Draw the Torque v/s speed characteristics of induction motor and show the range in which Induction motor operates. 5M
- b) A 4 pole three phase induction motor runs at 1470 rpm, when connected to a 50 Hz supply, find the % slip and the frequency of the rotor currents 5M
- c) With a neat circuit explain how stepper motor operates. 5M

Hall Ticket No

--	--	--	--	--	--	--	--	--	--

Question Paper Code : A1204



VARDHAMAN COLLEGE OF ENGINEERING
(AUTONOMOUS)

B. Tech III Semester Regular Examinations, December - 2013

(Regulations: VCE-R11)

DC MACHINES

(Electrical and Electronics Engineering)

Date : 4 December, 2013

Time : 3 Hours

Max. Marks : 75

Answer ONE question from each Unit

All Questions Carry Equal Marks

All parts of the question must be answered in one place only

Unit - 1

1. a) By means of block diagram represent the flow of energy during the conversion of electrical energy into mechanical energy. Also explain what is meant by coupling field. 7M
- b) The relationship between mmf ξ , flux Φ and the position coordinate x is given by $\xi = \Phi^2 x^2$. Find the mechanical force f acting in the x direction using
 - i. Energy of the system
 - ii. Co-energy concept 8M
2. a) Give the examples of single excited and doubly excited electromechanical energy conversion devices. 5M
- b) Two coils have self and mutual inductances of 10M
$$L_{11} = L_{22} = \frac{2}{(1+2x)}$$
 and $M_{12} = (1-2x)$

If the current I_1 is maintained constant at 5A and I_2 at -2A, find the mechanical work done when x increases from 0 to 0.5m. What is the direction of force developed?

Unit - 2

3. a) Define Armature Reactions. The effect of armature reaction is to decrease the flux under one pole tip and to increase it under the other pole tip. Explain this with respect to a dc generator by using the suitable diagram. 7M
- b) Develop from first principle, EMF equations for a dc. machine. 4M
- c) Four terminals of a dc shunt machine are available, but these are unmarked. How would you identify the field and armature terminals? 4M
4. a) The terminal voltage of a 8 pole dc. shunt generator with 780 wave connected armature conductors and running at 500 rpm is 240 V. The armature resistance is 0.24Ω and the field resistance is 240Ω . Find the armature current, the induced emf and the flux per pole if load resistance is 12Ω . 7M
- b) What is commutation? Explain the process of commutation in a dc. machine. 8M

Unit - 3

5. a) Explain the external (V/I) characteristics for a shunt, series generator and compare them. 8M
- b) A 6-pole wave connected dc machine has 300 armature conductors and each conductor is capable of carrying 80A without excessive temperature rise. The flux per pole is 0.015 Wb and the machine is driven at 1800 rpm. Calculate the total current, emf, power developed in the armature. 7M

Cont...2

6. a) A 4-pole compound generator has armature, series field and shunt field resistances of 1Ω , 0.5Ω and 100Ω respectively. This generator delivers 4kW at a terminal voltage of 200 V . Allowing 1V per brush for contact drop, calculate for both short-shunt and long-shunt connections 8M
- i. The generated emf and
 - ii. The flux per pole if the armature has 200 lap-connected conductors and is driven at 750rpm .
- b) Explain the voltage build up process in dc shunt generators. It is found that the voltage of a dc shunt generator does not build up. Explain the various possible causes of this failure. 7M

Unit - 4

7. a) The armature of a 6 pole lap wound dc shunt motor takes 400 A at a speed of 350 rpm . The flux per pole is 80 m Weber's , the number of turns is 600 and 3% of torque is lost in friction and iron losses. Calculate the brake horse power, back emf and supply voltage if armature resistance is 0.1Ω . 8M
- b) Draw a neat labeled diagram of a three point starter used for starting of shunt motors. 7M
8. a) Explain the significance of back emf in a dc machine. 5M
- b) A 4 pole dc motor runs at 600 rpm on full load taking 25 A at 450 V . The armature is lap wound with 500 conductors and flux per pole is expressed by relation $\Phi = 1.7 \times 10^{-2} \times I^{0.5}$ Weber's where I is the motor current. If supply voltage and torque are both halved, calculate the speed at which the motor will run. Ignore stray losses. 10M

Unit - 5

9. a) Derive the efficiency of dc machine as motor and generator using Swinburne's test. 8M
- b) A full load brake test on a small dc shunt motor, gave the following data: 7M
- Spring balance readings 25kg and 9 kg
Outside pulley diameter 19.5 cm
Motor speed 1500 rpm
Applied voltage 230V
Line current 12.5A
- Calculate the shaft torque, shaft power and the motor efficiency at rated load.
10. a) Explain the various losses in dc machine and draw the power flow diagrams for long shunt 10M
- i. dc compound generator
 - ii. dc compound motor
- b) A 200 V dc shunt motor delivers an output of 17 kW with an input of 20 kW . The field winding and armature circuit resistances are 50Ω and 0.04Ω respectively. Calculate the value of total armature ohmic losses at maximum efficiency. 5M

--	--	--	--	--	--	--	--	--	--



VARDHAMAN COLLEGE OF ENGINEERING
(AUTONOMOUS)

B. Tech III Semester Regular Examinations, December - 2013

(Regulations: VCE-R11)

THERMODYNAMICS

(Common to Mechanical Engineering & Aeronautical Engineering)

Date : 4 December, 2013

Time : 3 Hours

Max. Marks : 75

Answer ONE question from each Unit

All Questions Carry Equal Marks

All parts of the question must be answered in one place only

Unit - 1

1. a) Distinguish between 7M
 - i. Intensive and extensive properties
 - ii. Thermal equilibrium and Mechanical equilibrium
 - iii. Adiabatic wall and a dia-thermal wall
- b) An engine cylinder has a piston of area 0.12m^2 and contains gas at a pressure of 1.5MPa . 8M
The gas expands according to a process which is represented by a straight line on a pressure volume diagram. The final pressure is 0.15MPa . Calculate the work done by the gas on the piston if the piston stroke is 0.30m .
2. a) Give the precise statement of first law of thermodynamics as applied in a closed system 7M
undergoing a process and hence prove that internal energy is a property.
- b) 1.5kg of gas undergoes a quasi-static process in which the pressure and specific volume 8M
are related by the equation $p = a + bv$, where a and b are constants. The initial and final pressures are 1000 kPa and 200 kPa respectively. The corresponding volumes are 0.2 m^3 and 1.2 m^3 . The specific internal energy of the gas is given by the relation $u = 1.5pv - 35$ where u is in kJ/kg , p is in kPa and v is in m^3/kg . Find the magnitude and direction of heat transfer and the maximum internal energy of the gas during the process.

Unit – 2

3. a) What is a heat engine? If all heat engines are operated between same temperature 8M
levels then show that the efficiency of reversible heat engines is more than the irreversible heat engines.
- b) A car not engine operates between T_1 and $T_2\text{ K}$. Work output of engine is 0.6 times heat 7M
rejected. Given that the difference in temperature between source and sink as 200°C find
 - i. Source temperature
 - ii. Sink temperature
 - iii. Engine efficiency
4. a) Represent the car not heat engine cycle on PV and TS diagrams and explain briefly 7M
- b) Prove that whenever a system executes a complete cyclic process the quantity 8M

$$\oint \left(\frac{\delta Q}{T} \right) \leq 0.$$

Unit - 3

5. a) Define the following which refers to water 6M
i. Dryness fraction
ii. Enthalpy of superheated steam
iii. Latent heat
b) The following observations were taken with a separating and a throttling calorimeter arranged in series. Water separated=2 kg, steam discharged from the throttling calorimeter=20.5 kg, temperature of steam after throttling=110°C, initial pressure=12 bar abs. barometer reading=760 mm of Hg, final pressure=5 mm of Hg. Estimate the quality of steam supplied. 9M
6. a) Explain 7M
i. Law of corresponding states
ii. Compressibility chart
b) A vessel of 2.75 m³ capacity contains 5 kg of oxygen at 300 K. Determine the pressure exerted by oxygen using Vander Waal's equation. Compare the result obtained if oxygen is treated as ideal gas. The constants appearing in the Vander Waal's equation having the values:
a = 139.35 * 10³ N m⁴ / (kg mol)² and b = 0.0314 m³/kg mol. 8M

Unit - 4

7. a) i. Define the terms partial pressure, mole fraction, volume fraction of a gas constituent in a mixture 8M
ii. State Dalton's law of partial pressure and derive an expression for the gas constant of a mixture of ideal gases.
b) A gas mixture consists of 6 Kmol of H₂ and 4 Kmol of N₂. Determine the mass of each gas and the gas constant of the mixture. 7M
8. a) What is meant by mass, volume and mole fractions? 7M
b) A mixture of hydrogen (H₂) and oxygen (O₂) is to be made so that the ratio of H₂ to O₂ is 2:1 by volume. If the pressure and temperature are 1 bar and 25°C respectively, calculate 8M
i. The mass of O₂ required
ii. The volume of container

Unit - 5

9. a) Derive an expression for the thermal efficiency of an air standard Otto cycle. State the assumptions made. 8M
b) The following particulars refer to four stroke diesel engine cycle. 7M
Compression ratio 21:1 and expansion ratio 10.5:1
Determine the cut off ratio and air standard efficiency
10. a) Derive an expression for thermal efficiency of air standard Diesel cycle in terms of compression ratio, cut off ratio and the adiabatic index. 8M
b) Otto cycle is designed to operate with the following data: 7M
Maximum cycle pressure and temperature -5 Mpa and 2250K
Minimum cycle pressure and temperature -0.1 Mpa and 300K
Determine network output per unit mass of working fluid and thermal efficiency
Take C_v=0.718 KJ/kg K

Hall Ticket No

--	--	--	--	--	--	--	--	--	--

Question Paper Code : A1104



VARDHAMAN COLLEGE OF ENGINEERING
(AUTONOMOUS)

B. Tech III Semester Regular Examinations, December - 2013

(Regulations: VCE-R11)

CONCRETE TECHNOLOGY

(Civil Engineering)

Date : 4 December, 2013

Time : 3 Hours

Max. Marks : 75

Answer ONE question from each Unit

All Questions Carry Equal Marks

All parts of the question must be answered in one place only

Unit - 1

1. a) What are the end products of hydration? Explain. 8M
b) What is the importance of sieve analysis in concrete Technology? 7M
2. List various field and laboratory tests conducted on cement? Explain any two from each. 15M

Unit - 2

3. a) What are the various factors affecting the workability of concrete? Explain. 8M
b) Explain the influence of bleeding and segregation on fresh concrete. 7M
4. a) Explain the different stages of manufacture of concrete. 8M
b) What is the relation between compressive and tensile strength of concrete? 7M

Unit - 3

5. a) What are the factors affecting the strength of concrete? 7M
b) How do you determine the flexural strength of concrete? What is its significance? 8M
6. a) With a neat graph, explain different moduli of elasticity of concrete. 7M
b) Explain the deformations of concrete which are independent of the load. 8M

Unit - 4

7. a) What are the various factors affecting the mix proportion? 7M
b) Explain the procedure of BIS method of mix design. 8M
8. Calculate the quantities of all the ingredients of M20 concrete using latest IS code method 15M
for the following details:

Cement – 43 Grade, Specific gravity-3.15,

Fine aggregate – Zone I, Specific gravity of 2.6, water absorption is 2%, free moisture is 3%.

Coarse aggregate – Crushed angular, 20mm down, Specific gravity is 2.67.

Chemical Admixture: Specific gravity is 1.145, Optimum dosage is 1%, water reduction is 20%.

Type of placement is Pumpable.

Exposure condition: Mild for RCC.

Slump requirement is 100mm. Assume the missing data if any and specify clearly.

Unit - 5

9. a) Explain the different types of fibres used for FRC 6M
b) Write short notes on HVFAC, SCC and light weight concrete 9M
10. a) Explain High density concrete and high performance concrete. 6M
b) What is polymer concrete? What are the various polymer materials used for concrete? 9M



VARDHAMAN COLLEGE OF ENGINEERING
(AUTONOMOUS)

B. Tech III Semester Regular Examinations, December - 2013

(Regulations: VCE-R11)

DIGITAL LOGIC DESIGN

(Common to Computer Science and Engineering, Information Technology,
Electronics and Communication Engineering & Electrical and Electronics Engineering)

Date : 6 December, 2013

Time : 3 Hours

Max. Marks : 75

Answer ONE question from each Unit

All Questions Carry Equal Marks

All parts of the question must be answered in one place only

Unit - 1

1. a) Perform the following operations indicating the complete procedure: 8M
- i. $(?)_2 = (53.6875)_{10}$
- ii. $(?)_{10} = (11111111.1011)_2$
- iii. $(?)_2 = (265.354)_8$
- iv. $(?)_8 = (010110101.011101100)_2$
- b) Find minimal SOP expression of the Boolean function 7M
 $Y(a,b,c,d) = abc + abd + a'bc' + cd + bd'$
2. a) Perform the following arithmetic using 2's complement method. 6M
- i. $\begin{array}{r} +6 \\ +9 \\ \hline \end{array}$ ii. $\begin{array}{r} -6 \\ +9 \\ \hline \end{array}$ iii. $\begin{array}{r} +6 \\ -9 \\ \hline \end{array}$
- b) Minimize the logic expression below and draw the logic circuit for the simplified expressions. $Y = \overline{A}B\overline{C} + \overline{A}BC + ABC$ 6M
- c) With examples explain the methods of signed binary numbers representation. 3M

Unit - 2

3. a) Using Quine-McLuskey method, determine the minimal sum for the Boolean function: 10M
 $f(w, x, y, z) = \sum m(1, 4, 6, 7, 8, 9, 10, 11, 15)$
- b) Realize the function: $f(w, x, y, z) = \sum m(0, 1, 5, 6, 7, 9, 12, 15)$ using a 4:1 MUX 5M
and external gates, considering w and z as select lines.
4. a) Simplify the logic function given below, using Map entered variable technique, 10M
considering 'z' as the map entered variable:
 $f(w, x, y, z) = \sum m(2, 3, 4, 5, 13, 15) + d(8, 9, 10, 11)$
- b) Find all the prime implicants of the following function using K-map: 5M
 $f(w, x, y, z) = \sum m(3, 4, 5, 7, 10, 12, 14, 15) + d(2)$

Unit - 3

5. a) Design a synchronous mod-6, counter with the following sequence: 10M
5, 6, 7, 8, 9, 10, 5.....
- b) Convert SR flip-flop to JK flip-flop. 5M
6. a) Briefly explain the 'race around' condition in a flip-flop. What are the ways of 10M
eliminating this condition? Explain any one in detail
- b) Design a 4-bit Binary ripple down-counter using a negative edge triggered D flip-flops 5M

Unit - 4

7. a) Design a combinational circuit using ROM that accepts a three bit binary number and produces its square at the output. 8M
b) Implement the multi-output function given using PLA. 7M
 $F_1 = AB' + AC + A'BC'$; $F_2 = (AC + BC)'$
8. a) What are the different Programmable Logic Devices used for digital system implementations? Explain them briefly. 7M
b) A multi-output function is defined by the switching functions; 8M
 $F_1 = \sum m(0, 1, 2, 4)$, $F_2 = \sum m(0, 5, 6, 7)$ and $F_3 = \sum m(0, 3, 5, 7)$. Prepare a PLA programming table for implementation.

Unit - 5

9. a) Explain the basic elements in ASM chart. 7M
b) Draw the state diagram, state table and ASM chart for the JK flip-flop. 8M
10. a) Explain the determination of state equivalence using implication table with an example. 8M
b) What is an ASM chart? Explain the difference between state diagram and ASM chart with an example. 7M

--	--	--	--	--	--	--	--	--	--



VARDHAMAN COLLEGE OF ENGINEERING
(AUTONOMOUS)

B. Tech III Semester Regular Examinations, December - 2013

(Regulations: VCE-R11)

MACHANICS OF SOLIDS

(Common to Mechanical Engineering & Aeronautical Engineering)

Date : 6 December, 2013

Time : 3 Hours

Max. Marks : 75

Answer ONE question from each Unit

All Questions Carry Equal Marks

All parts of the question must be answered in one place only

Unit - 1

1. a) Draw the typical stress strain curve for a ductile material, show and briefly explain the salient points. 7M
- b) The diameter of a specimen is found to reduce by 0.004 mm, when it is subjected to a tensile force of 19 KN. Initial diameter of the specimen is 20 mm. Taking modulus of rigidity for the specimen as $0.4 \times 10^5 \text{ N/mm}^2$, determine the values of young's modulus and Poisson's ratio. 8M
2. a) A brass bar having cross sectional area 300 mm^2 is subjected to axial forces as shown in fig.1. Determine the total elongation of the bar taking E as 84 GPa. 7M

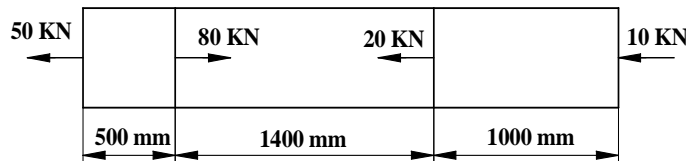

fig.1

- b) A rod of steel is 20 m long at a temperature of 20°C . Taking $\alpha = 12 \times 10^{-6}/^\circ\text{C}$ and $E = 200 \text{ GPa}$, determine; 8M
 - i. The free expansion of the rod when the temperature is raised to 650°C .
 - ii. The thermal stress induced when the expansion of the rod is prevented.
 - iii. Thermal stress when the rod is permitted to expand by 5.8 mm.

Unit - 2

3. a) A cantilever is loaded with several point loads as shown in fig.2. Draw the SF AND BM diagrams. 6M

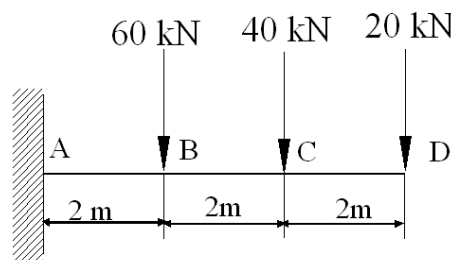

fig.2

- b) The simply supported beam shown in fig.3 carries two concentrated loads and a 9M uniformly distributed load. Draw the SFD and BMD.

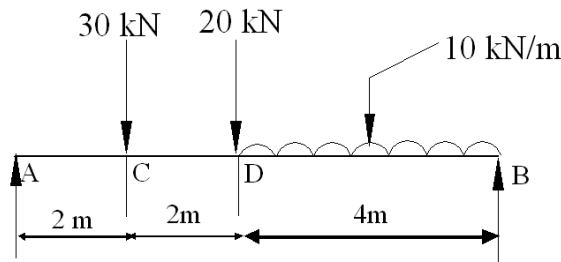

fig.3

4. a) Explain (i) Pure bending (ii) Sign conventions for shear force & bending moment. 4M
 b) Draw the shear force and bending moment diagrams for a simply supported beam subjected to the forces and moments as shown in fig.4 Also locate the point of contraflexure. 11M

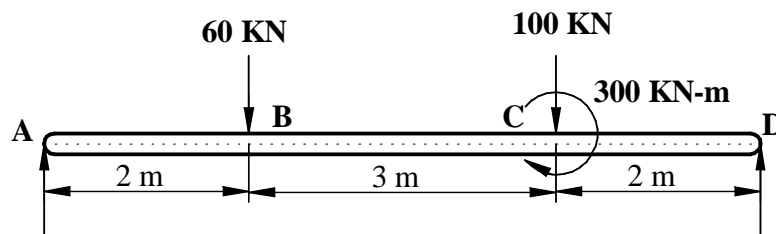

fig.4

Unit - 3

5. a) State the assumptions made in deriving the bending equation. Write down the bending equation and name each term and its unit. 5M
 b) A 2m long steel beam of rectangular cross section of width 60 mm and depth 120 mm is simply supported at its ends. Determine the maximum point load P that can be applied at the midpoint of the beam taking the allowable stress in the material as 90 MPa. 10M
6. a) Explain (i) Moment of resistance (ii) Flexural rigidity as applied to beams 4M
 b) A beam with symmetric I section of flange width 180 mm and total depth of 310 mm and flange & web thickness 15 mm is subjected to a bending moment of 120 kN-m shear force of 60 kN. Determine & sketch the bending stress and shear stress distribution along the depth of the section. 11M

Unit - 4

7. a) Explain the terms (i) Perfect frame (ii) Imperfect frame. 4M
 b) A truss of span 7.5m carries a point load of 1 kN at joint D as shown in the fig.5 below. Determine the reactions and forces in the members of the truss. 11M

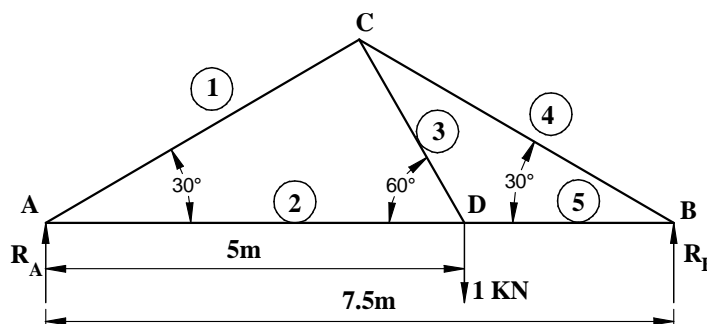

fig.5

8. a) With usual notations, obtain the expressions for slope & deflection at the free end of a cantilever beam subjected to uniformly distributed load. 8M
- b) A 2m long cantilever is subjected to a UDL of 10 KN/m throughout its length and a vertically downward point load of 20 KN at its free end. Taking $E = 200$ GPa, and maximum deflection as 0.3 mm, determine the width and depth of the rectangular cross section of the beam. Assume depth=twice the width. 7M

Unit - 5

9. a) Show the Change in dimensions of thin cylindrical shell (Diameter, length and volume). 9M
- b) A thick cylinder of internal diameter 160 mm is subjected to an internal pressure 40 N/mm². If the allowable stress in the material is 120 N/mm², find the thickness required. 6M
10. A compound cylinder has inner radius 200 mm, radius at common surface 250 mm and outer radius is 300mm. Radial pressure at common surface is 6 N/mm². What are the final hoop stresses after a fluid is admitted at an internal pressure of 80 N/mm²? Sketch the variation of hoop and radial stresses. 15M

--	--	--	--	--	--	--	--	--	--



VARDHAMAN COLLEGE OF ENGINEERING
(AUTONOMOUS)

B. Tech III Semester Regular Examinations, December - 2013

(Regulations: VCE-R11)

BUILDING MATERIALS AND CONSTRUCTION

(Civil Engineering)

Date : 6 December, 2013

Time : 3 Hours

Max. Marks : 75

Answer ONE question from each Unit

All Questions Carry Equal Marks

All parts of the question must be answered in one place only

Unit - 1

1. a) What is meant by dressing of stone? Explain with sketch different types of dressed stone generally used? 7M
- b) What are the constituents of good brick earth? Briefly explain the functions of these ingredients in brick 8M
2. a) Differentiate clamp burning and kiln burning. 7M
- b) Mention the properties of good roofing tile. Explain briefly Mangalore tile, Encaustic tiles. 8M

Unit - 2

3. a) What are the various laboratory tests conducted on cement? Explain briefly. 8M
- b) What is seasoning of timber? Why it is done? 7M
4. a) How the workability of concrete is measured using slump test? 7M
- b) Briefly explain about the mineral admixtures for concrete? 8M

Unit - 3

5. a) Derive an expression for the depth of concrete block required for a strip footing of a wall. 7M
- b) Name different types of partition walls. Explain with sketches any one type of partition wall suitable for domestic building. 8M
6. a) Draw a neat sketch of elevation of English bond and explain its features. 8M
- b) What is raft foundation? What are the situations for which a raft foundation is preferred? Draw the sketch of raft foundation. 7M

Unit - 4

7. a) Classify various types of arches. Draw neat sketch of segmental arch naming different parts. 8M
- b) Explain with sketches the following: 7M
 - i. RCC lintel
 - ii. Timber lintel
8. a) State briefly the essential requirement of a good roof. Compare merits and demerits of flat and pitches roof. 7M
- b) Explain the procedure of constructing the following types of flooring 8M
 - i. Terrazzo flooring
 - ii. Mosaic flooring

Unit - 5

9. a) What do you understand by underpinning? Where do you require it? Explain the pit method of underpinning 9M
- b) Describe the method of damp proofing for the following 6M
- i. Foundations
 - ii. Basement in an area having high water table
10. a) Explain with sketch form work for a beam and slab floor 7M
- b) Explain the procedure of painting 8M
- i. New wood and building surface
 - ii. Repainting on old work of wood and buildings

--	--	--	--	--	--	--	--	--	--



VARDHAMAN COLLEGE OF ENGINEERING
(AUTONOMOUS)

B. Tech III Semester Regular Examinations, December - 2013

(Regulations: VCE-R11)

ELECTRONIC DEVICES AND CIRCUITS

(Common to Computer Science and Engineering & Information Technology)

Date : 9 December, 2013

Time : 3 Hours

Max. Marks : 75

Answer ONE question from each Unit

All Questions Carry Equal Marks

All parts of the question must be answered in one place only

Unit - 1

1. a) Briefly explain zener and avalanche breakdown. 7M
- b) The reverse saturation current of an ideal germanium diode at 125°C is 30μA. Find the dynamic resistance at 125°C for a 0.2V. 8M
 - i. Forward bias
 - ii. Reverse bias

Take $\eta=1$.
2. a) Show that % regulation = $(R_f/R_L) \times 100\%$ for both half wave and a full wave rectifier. 10M
- b) Calculate the value of C that has to be used for the capacitor filter of a full wave rectifier to get a ripple factor of 0.01%. The rectifier supplies a load of 2kΩ while the supply frequency is 50Hz. 5M

Unit - 2

3. a) Explain the operation of transistor in CB configuration along with input and output characteristics. 7M
- b) A fixed bias circuit has $R_C = 3.3K\Omega$ and $V_{CC} = 15V$. The transistor has a typical current gain of 60 with minimum and maximum of 30 and 90 respectively. Select the value of R_B to give $V_{CE} = 5V$. 8M
4. a) What is meant by transistor biasing? Compare different biasing methods used for transistor biasing with respect to stability. 5M
- b) Determine V_C and V_B for the network of fig.1 shown below. 10M

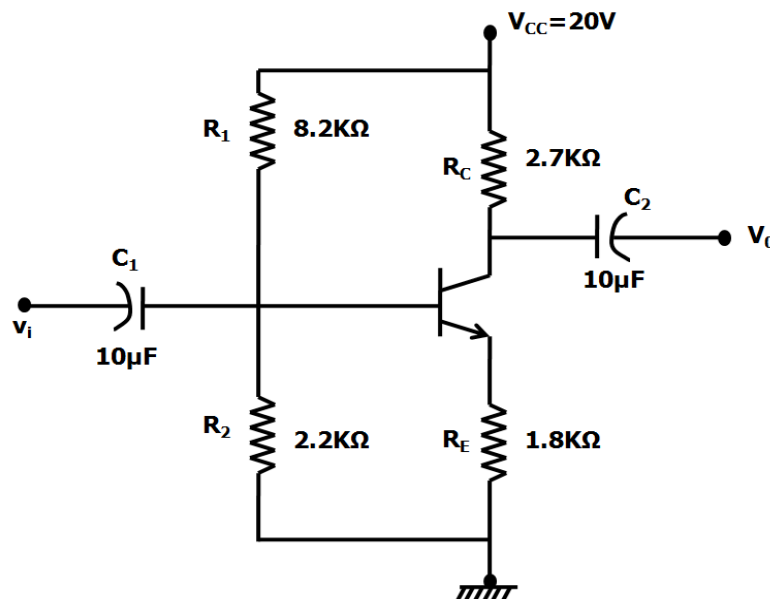

fig.1

Unit - 3

5. a) Derive an expression for voltage gain and output impedance of a CE transistor amplifier in terms of h-parameters. 8M
- b) A transistor is connected as a common – base amplifier is driving a load of 10KΩ. It is supplied by a source of 1KΩ internal resistance. The hybrid parameters of the transistor used are $h_{ib} = 22\Omega$, $h_{fb} = -0.98$, $h_{rb} = 2.6 \times 10^{-4}$, $h_{ob} = 1/2M\Omega$. Find 7M
- i. Current gain.
 - ii. Current gain with source resistance.
 - iii. Voltage gain.
 - iv. Output impedance.
6. With a neat circuit diagram, design a emitter follower having, $R_i = 500K\Omega$ and $R_o = 20\Omega$. Assume $h_{fe} = 50$, $h_{ie} = 1K$ and $h_{oe} = 2.5\mu A/V$, for the transistor to be used. Also find A_i and A_v for the emitter follower. Determine R_i and the necessary R_L so that $A_v = 0.999$. 15M

Unit - 4

7. a) Define μ , g_m and r_d of a JFET. 5M
- b) With the aid of neat diagrams, explain the construction, principle of operation and characteristics of an n channel enhancement MOSFET. 10M
8. a) List the important characteristics of FET over BJT. 6M
- b) Discuss the construction and characteristics of an n channel JFET with neat diagrams. 9M

Unit - 5

9. a) What are the advantages of negative feedback system? 7M
- b) Derive an expression for frequency of oscillation of Colpitts oscillator. 8M
10. a) What is Barkhausen Criterion? Explain how oscillations start in an oscillator. 8M
- b) The following circuit parameter values are given for the Hartley oscillator. $L_1 = 750 \mu H$, $L_2 = 750 \mu H$, $LRFC = 0.5 mH$, $C = 150 PF$, $C_L = 10 \mu F$, $h_{fe} = 50$ 7M
- i. Calculate the frequency of oscillations
 - ii. Check to make sure that the conditions for oscillation is satisfied.



VARDHAMAN COLLEGE OF ENGINEERING
(AUTONOMOUS)

B. Tech III Semester Regular Examinations, December - 2013

(Regulations: VCE-R11)

ELECTRONIC DEVICES

(Common to Electronics and Communication Engineering &
Electrical and Electronics Engineering)

Date : 9 December, 2013

Time : 3 Hours

Max. Marks : 75

Answer ONE question from each Unit

All Questions Carry Equal Marks

All parts of the question must be answered in one place only

Unit - 1

1. a) Draw a neat block diagram of a CRO and explain the importance of each block. 7M
- b) Two parallel plates are spaced 'd' meters apart, produce an electric field intensity 'E' v/m with a potential difference of 'V_p' volts across them. If an electron is moving in this electric field with initial velocity of 'u_{ox}' m/s, find the distance covered by the electron in 't' seconds. 8M
2. a) With a neat block diagram of a CRT, explain how the electron beam is focused and accelerated in a CRO. 8M
- b) In a diode, the cathode and anode plates are parallel placed 5mm apart. A potential difference of 200V is maintained between the two plates. Calculate the velocity and the distance travelled by an electron after 0.5ns 7M
 - i. With zero initial velocity.
 - ii. With an initial velocity of 2×10^6 m/s.

Unit - 2

3. a) Find the maximum wavelength of a photon that can excite electrons by imparting sufficient energy to cross the forbidden energy gap in 8M
 - i. Silicon with $E_G=0.72$ eV, and
 - ii. Gallium Arsenide with $E_G=1.43$ eV.
- b) Draw a neat VI characteristic curve for the junction diode and explain the diode behavior using the diode current equation. 7M
4. a) Draw a neat piece wise linear equivalent circuit for the PN junction and explain different components in the equivalent circuit. 5M
- b) Calculate the thermal voltage V_T at room temperature using (i) The values q, k and T 4M
 (ii) Only the value of T.
- c) Fig.1 indicates VI curves for a certain silicon diode. From the curve determine the diode dc resistance at I_D value of 2mA, 30mA and 40mA. 6M

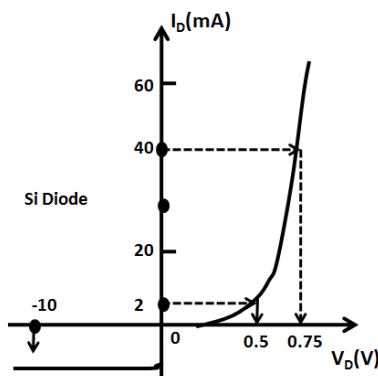

fig.1

:: 2 ::

Unit – 3

- 5. a) Draw the circuit diagram of half-wave rectifier and explain its operation with the help of waveforms. 8M
- b) Estimate the ripple value in a HWR with $10\mu\text{F}$ C-filter, given the input frequency for the rectifier is 100Hz and the load is 5mA at 15V. 7M
- 6. a) With a simple block diagram, explain the role of different components in a regulated power supply. 7M
- b) A 2-diode FWR has the transformer secondary voltage $V_1 = 15 \sin 100t$; find the dc output voltage, rectification efficiency and output frequency of the rectifier. The Si diodes used are assumed to have a forward resistance of 15Ω each and load resistance is $1.5\text{k}\Omega$. 8M

Unit - 4

- 7. a) Discuss the input and output characteristics of common emitter configuration. 8M
- b) For a transistor, the value of α is specified to be 0.98 at a particular collector base voltage. The value of α increase by 0.5% when the collector-base voltage is increased. Find the percentage change in the value of β . Comment result. 7M
- 8. a) With a neat structure explain the principle of operation of enhancement MOSFET. 9M
- b) For the common-base configuration shown in fig.2, determine the values of base current (I_B), emitter current (I_E) and collector current (I_C). It is given that the value of α is 0.95. 6M

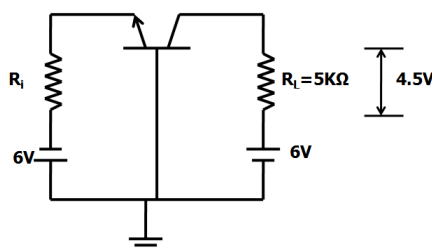

fig.2

Unit - 5

- 9. a) What makes FET a better choice over BJT in system designs? Critically compare them to justify your answer. 8M
- b) For the fixed bias circuit shown in fig.3, determine the operating point if $I_{DSS}=10\text{mA}$ and $V_p=-4\text{V}$. 7M

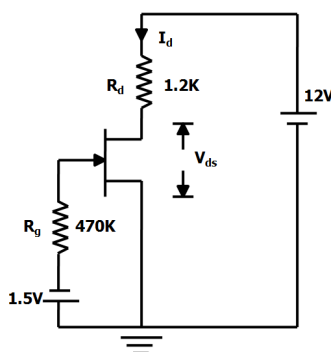

fig.3

- 10. a) With a circuit diagram explain the fixed bias configuration for N-channel JFET. 7M
- b) Determine the stability factor $S_{I_{CO}}$, $S_{V_{BE}}$ and S_{β} for the self-bias circuit with $R_B = 300\text{k}\Omega$, $R_E = 2\text{k}\Omega$, $I_C = 2\text{mA}$ and $\beta = 50$. Also determine the total change in collector current when the temperature changes from $+25^\circ\text{C}$ to $+175^\circ\text{C}$. The various transistor parameters at different temperatures are listed in table below: 8M

T °C	I_{CO}	β	V_{BE}
-65	2×10^{-4}	25	0-85

25	0.2	50	0.7
100	25	80	0.5
175	3×10^3	125	0.32

--	--	--	--	--	--	--	--	--	--



VARDHAMAN COLLEGE OF ENGINEERING
(AUTONOMOUS)

B. Tech III Semester Regular Examinations, December - 2013

(Regulations: VCE-R11)

MACHANICS OF FLUIDS

(Common to Mechanical Engineering, Aeronautical Engineering & Civil Engineering)

Date : 9 December, 2013

Time : 3 Hours

Max. Marks : 75

Answer ONE question from each Unit

All Questions Carry Equal Marks

All parts of the question must be answered in one place only

Unit - 1

1. a) Explain the terms: (i) dynamic viscosity (ii) Kinematic Viscosity. Give their dimensions 6M
- b) A 15cm diameter vertical cylinder rotates concentrically inside another cylinder of diameter 15.10 cm. Both cylinders are 25 cm high. The space between the cylinders is filled with a liquid whose viscosity is unknown. If a torque of 12.0 Nm is required to rotate the inner cylinder at 100 rpm. Determine the viscosity of the fluid. 9M
2. a) What is the difference between U-tube differential manometers and inverted U-tube differential manometers? Where are they used? 8M
- b) What are the gauge pressure and absolute pressure at 3m below the free surface of a liquid having a density of $1.53 \times 10^3 \text{ kg/m}^3$, if the atmospheric pressure is equivalent to 750 mm of mercury? The specific gravity of mercury is 13.6 and density of water = 1000 kg/m^3 . 7M

Unit - 2

3. a) Obtain an expression for continuity equation for a three-dimensional flow. 7M
- b) The velocity potential function is given by $\Phi = 5(x^2 - y^2)$. Calculate the velocity components at the point (4,5) 8M
4. a) Explain about velocity potential. 7M
- b) A stream function is given by $\Psi = 5x - 6y$. Calculate the velocity components and also magnitude and direction of the resultant velocity at any point. 8M

Unit - 3

5. a) From the principle of Euler's equation of motion derive Bernoulli's equation. 10M
- b) Water is flowing up to a pipe of 5 cm diameter under a pressure of 29.43 N/cm^2 (gauge) and with mean velocity of 2.0 m/sec. Find the total head or total energy per unit weight of the water at a cross section which is 5 m above the datum line. 5M
6. a) What is a minor energy loss (head losses)? Derive an expression for determining loss of head due to sudden enlargement. 8M
- b) At a sudden enlargement of a water main from 240 mm to 480 mm diameter the hydraulic gradient rises by 10mm. Estimate the rate of flow. 7M

Unit - 4

7. a) Explain about Laminar boundary layer. 7M
- b) What are the methods of preventing the separation of boundary layer? 8M
8. a) Explain about turbulent boundary layer 7M
- b) Oil with a free stream velocity of 2 m/s flows over a thin plate 2 m wide and 2 m long. Calculate the boundary layer thickness and the shear stress at the trailing end point and determine the total surface resistance of the plate. Take specific gravity as 0.86 and kinematic viscosity as $10^{-5} \text{ m}^2/\text{s}$. 8M

Unit - 5

9. a) What is the relation between pressure and density of a compressive fluid for 5M
i. Isothermal process and
ii. Adiabatic process.
- b) A gas with a velocity of 300 m/sec is flowing through a horizontal pipe at a section 10M
where pressure is $6 \times 10^4 \text{ N/m}^2$ (absolute) and temperature 40°C . The pipe changes in diameter and at this section the pressure is $9 \times 10^4 \text{ N/m}^2$. Find the velocity of the gas at this section if the flow of the gas is adiabatic.
10. a) Define Mach number. What is the significance of Mach number in compressible fluid 8M
flows?
- b) Find the sonic velocity for the following fluids: 7M
i. Crude oil of specific gravity 0.8 bulk modulus 153036 N/cm^2 .
ii. Mercury having a bulk modulus of 2648700 N/cm^2 .

Hall Ticket No

--	--	--	--	--	--	--	--	--	--

Question Paper Code : A1506



VARDHAMAN COLLEGE OF ENGINEERING
(AUTONOMOUS)

B. Tech III Semester Regular Examinations, December - 2013
(Regulations: VCE-R11)

OBJECT ORIENTED PROGRAMMING THROUGH JAVA

(Common to Computer Science and Engineering & Information Technology)

Date : 11 December, 2013

Time : 3 Hours

Max. Marks : 75

Answer ONE question from each Unit

All Questions Carry Equal Marks

All parts of the question must be answered in one place only

Unit - 1

1. a) What is Object Oriented Programming and Discuss the benefits of Object Oriented Programming. 7M
- b) Write a java program to print a fibonacci series 1,1,2,3..... upto the need value n given by the user. 8M
2. a) Explain briefly widening and narrowing conversion. 7M
- b) Design a class named as Square having variables height and width. Define overloaded constructors to assign value to variables. Write a test program for the same. 8M

Unit - 2

3. a) Design a class called person with FirstName and LastName as attributes. Use this class as base to design another class called student having id, standard and instructor as its attributes. Similarly design yet another class called teacher from person having attributes subject and salary. Define constructor and display methods. Write a test driver program for the same. 8M
- b) Illustrate method overriding with a suitable example. 7M
4. a) Describe access control with respect to packages in java. 8M
- b) Design two packages namely MyBalance and MyTest. The MyBalance package must have a class called Balance that has few attributes of bank customer and methods to operate on the attributes. Design a test driver class called TestBalance which will print the current balance. 7M

Unit - 3

5. a) Write a program to create a class MyThread in this class a constructor, call the base class constructor, using super and starts the thread. The run method of the class starts after this. It can be observed that both main thread and created child thread are executed concurrently. 8M
- b) Create a multithreaded program by creating a subclass of Thread and then creating, initializing, and starting two Thread objects from your class. The threads will execute concurrently and display Java is hot, aromatic, and invigorating to the console window. 7M
6. a) Write a program to illustrate usage of try/catch with finally clause. 7M
- b) Write a java program that create 3 threads that the 1st thread to display GOOD MORNING for every 1second, 2nd thread to display HELLO for every 2seconds and the 3rd thread to display WELCOME for every 3 seconds. 8M

Unit - 4

7. a) Write a program that displays the x and y position of the cursor movement using Mouse. 8M
- b) Write an AWT program that creates three labels and adds them to an applet window. 7M
8. a) Illustrate different types of adjustment events in handling scroll bars. 8M
- b) What is an Anonymous Inner Classes? Illustrates how an anonymous inner class can facilitate the writing of event handlers. 7M

Cont...2

Unit - 5

- | | | |
|-----|--|----|
| 9. | a) Write a Applet program that automatically display the text with Font Style, Font type. | 7M |
| | b) Explain briefly the methods that are called during applet initialization and termination. | 8M |
| 10. | a) Explain the following swing components with their constructors and methods | 8M |
| | i. JLabel | |
| | ii. JRadioButton | |
| | b) Write an applet program to display sum of two numbers entered in TextField. | 7M |



VARDHAMAN COLLEGE OF ENGINEERING
(AUTONOMOUS)

B. Tech III Semester Regular Examinations, December - 2013

(Regulations: VCE-R11)

SIGNALS AND SYSTEMS

(Electronics and Communication Engineering)

Date : 11 December, 2013

Time : 3 Hours

Max. Marks : 75

Answer ONE question from each Unit

All Questions Carry Equal Marks

All parts of the question must be answered in one place only

Unit - 1

1. a) Let $x(t)$ and $y(t)$ be given as in fig.1 below. Sketch the following signals. 8M

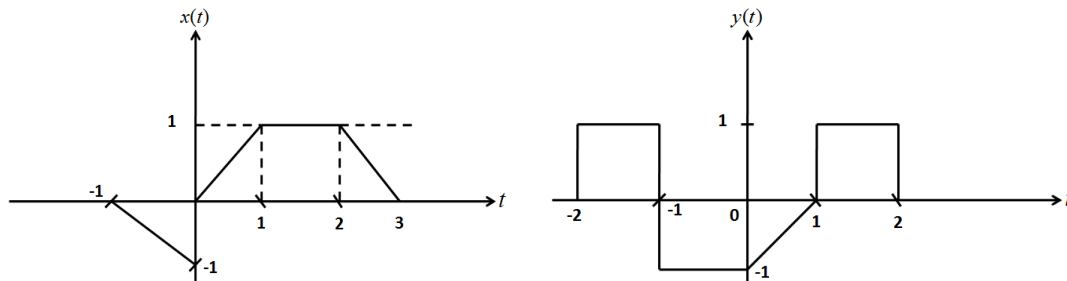

fig.1

- b) Find the trigonometric Fourier series of the periodic signal $x(t)$ described by 7M

$$x(t) = \begin{cases} -A; & \text{if } -\pi < t < 0 \\ A; & \text{if } 0 < t < \pi \end{cases}$$

2. a) Classify the following signals as energy signals, power signals or neither 6M

i. $x[n] = 2^n u[-n]$

ii. $x[n] = \cos(n\pi)$

iii. $x[n] = (j)^n + (+j)^{-n}$

- b) Find the complex Fourier series coefficients for the function $x(t)$ and plot its power spectrum. 9M

$$x(t) = 4 + 2 \cos 3t + 3 \sin 4t$$

Unit - 2

3. a) Find the Fourier transform of the following signals: 7M

i. $x_1(t) = \text{sgn}(t)$

ii. $x_2(t) = u(t)$

- b) State and prove the Time convolution and Frequency convolution properties of Fourier transform. 8M

4. a) Find the Fourier Transform of the function 6M

$$x(t) = te^{-2t} u(t)$$

- b) Using the properties of Fourier transform, find the Fourier transform of the signal 9M

$$x(t) = \frac{d}{dt} [te^{-2t} \sin(t) u(t)]$$

Unit - 3

5. a) The input and impulse response of a linear time-invariant system is shown in fig.2. Find the output of the system using graphical convolution. 10M

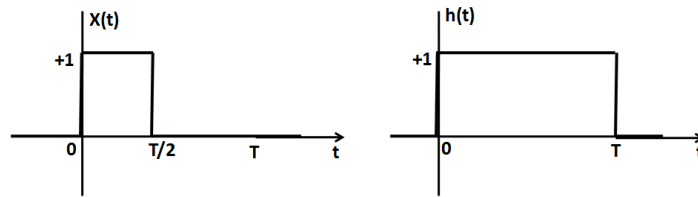

fig.2

- b) Define the cross-correlation of two signals. State the properties of correlation functions. 5M
6. a) The impulse response of a continuous-time LTI system is $h(t) = 5e^{-3t}u(t)$ 10M
- i. Verify whether the system is causal, memory and stable.
- ii. Find the response of the system for the input, $x(t) = 3u(t) + 2u(t-1)$.
- b) Derive the conditions for distortion-less transmission of a signal through a linear time-invariant system. 5M

Unit - 4

7. a) Find the Laplace transform of the signal $x(t) = e^{-a|t|}$ 8M
- b) State and prove differentiation property for Laplace transform. 7M
8. a) Find the inverse unilateral Laplace transform of $X(s) = \frac{s}{(s^2 + 5s + 6)}$ 6M
- b) Using the convolution property of Laplace transform find $y(t) = x_1(t) * x_2(t)$ 9M
 $x_1(t) = e^{-3t}u(t)$ and $x_2(t) = u(t-2)$

Unit - 5

9. a) Consider the continuous time signal $x(t) = A \cos(2\pi f_1 t) \cos(2\pi f_2 t)$. Plot the spectrums of the discrete time signal $x(nTs)$ derived by sampling $x(t)$ for the sampling rates ($f_2 > f_1$) 6M
 $f_s = 2(f_1 + f_2)$.
 $f_s = 3(f_1 + f_2)$.
- b) Explain the natural sampling with relevant waveforms. Give all the time – domain and frequency domain equations. 9M
10. a) Find the Z transform of the sequence $x[n] = -b^n u[-n-1]$. Find the poles and draw the region convergence. 7M
- b) Find the inverse Z transform of the sequence 8M

$$X(Z) = \frac{Z}{3Z^2 - 4Z + 1}; \text{ ROC } |Z| > 1$$



VARDHAMAN COLLEGE OF ENGINEERING
(AUTONOMOUS)

B. Tech III Semester Regular Examinations, December - 2013

(Regulations: VCE-R11)

NETWORK ANALYSIS

(Electrical and Electronics Engineering)

Date : 11 December, 2013

Time : 3 Hours

Max. Marks : 75

Answer ONE question from each Unit

All Questions Carry Equal Marks

All parts of the question must be answered in one place only

Unit - 1

1. a) State and explain Superposition theorem with an example. 7M
- b) In the circuit shown in fig.1, the resistance R is changed from 5 to 10 Ω, verify the Compensation theorem

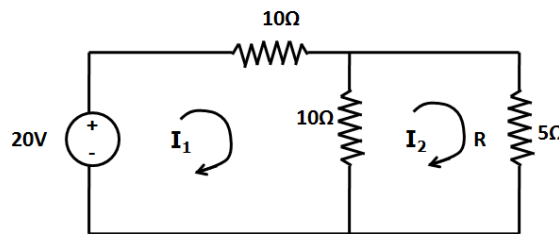

fig.1

2. a) State and explain Reciprocity theorem. 8M
- b) For the circuit shown in fig.2 using Millman's theorem, find the current in the load impedance, $Z_L = (2+j4)\Omega$. 7M

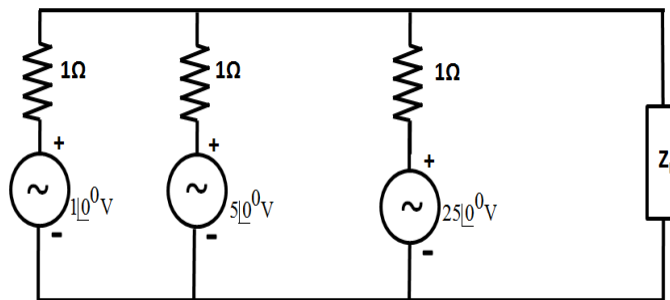

fig.2

8M

Unit - 2

3. a) A balanced Y load of 25-Ω resistors is connected to a 480-V, ABC, three-wire, three-phase source. Find the reading of a wattmeter connected with its current coil in line A and its potential coil across lines A and B. The ± terminal of the current coil is toward the source, and the ± terminal of the potential coil is at line A. 8M
- b) Find the equivalent resistance R_{ab} for the circuit shown in fig.3. 7M

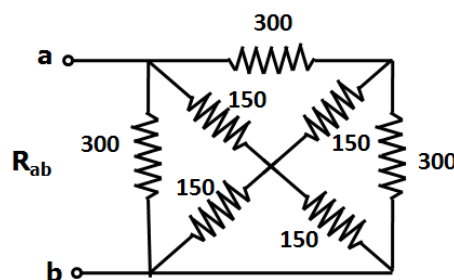

fig.3

4. a) A balanced star-connected load is supplied from a balanced 3-phase, 400V, 50Hz system. The current in each phase is 30A and lags 30° behind the phase voltage. Find the total power, phase voltage draw the phasor diagram. 7M
- b) Three identical impedances of $12\angle 30^\circ \Omega$ are connected in delta and another set of three identical impedances of $5\angle 45^\circ \Omega$ are connected in star. Both these sets are connected across a 3 phase, 3 wire, 400 V supply. Find the line current and the total power supplied. 8M

Unit - 3

5. a) Derive an expression for a transient current in D.C. voltage of V volts , connected through a switch S to a series RL circuit. 7M
- b) In the network shown in fig.4, 'k' is changed from position a to b at t=0. Solve for i, di/dt, d^2i/dt^2 at t=0+, if R=1000 Ω , L=1H, C=0.1 μ F and V=100V. Assume that the capacitor is initially uncharged. 8M

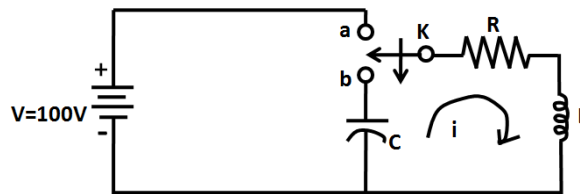

fig.4

6. a) In the circuit shown in fig.5, V=10V, R=10 Ω , L=1H, C=10 μ F and $V_c(0)=0$, find i, di/dt, d^2i/dt^2 at t=0+. 7M

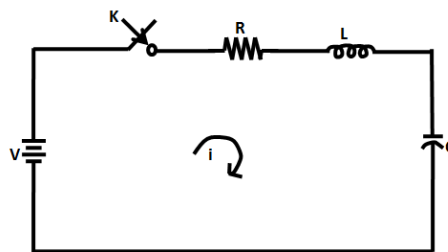

fig.5

- b) What is the inductance of a coil for which a changing current increasing uniformly from 30 mA to 80 mA in 100 μ s induces 50 mV in the coil? 8M

Unit - 4

7. a) Design a K-type band pass filter having cut-off frequency of 1KHz and 10 KHz, design impedance of 500 Ω . 8M
- b) Design a band elimination filter having, design impedance of 500 Ω and cut off frequencies $f_1=2$ KHz and $f_2=6$ KHz. 7M
8. a) Define Attenuator .Explain the different types of Attenuators. 8M
- b) Explain the design principle for a symmetrical T- attenuator. 7M

Unit - 5

9. a) 120V source is connected to a series circuit consisting of a 24 Ω inductive reactance and a resistor which is variable between the limits of 7 Ω and 55 Ω . Draw the current locus showing the current range, and indicate on the circle diagram, maximum and minimum currents and phase angles between the reference voltage phasor and the maximum and minimum currents. 8M
- b) A 220 V source is connected to a series RLC circuit consisting of 12 Ω resistance, 16 Ω capacitive reactance and variable inductance. The inductive reactance can be varied from 0 to 96 Ω . Draw the current locus giving the current range. 7M

10. a) State and prove the following properties of Fourier Series 7M
i. Time shift
ii. Scaling
- b) Obtain the trigonometric Fourier Series representation of the periodic signal as Shown in fig.6. 8M

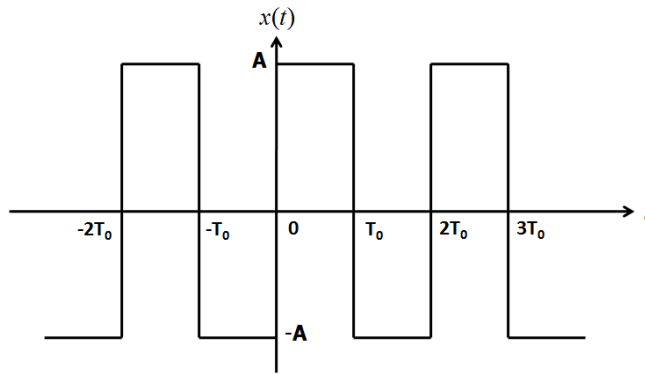

fig.6

--	--	--	--	--	--	--	--	--	--



VARDHAMAN COLLEGE OF ENGINEERING
(AUTONOMOUS)

B. Tech III Semester Regular Examinations, December - 2013

(Regulations: VCE-R11)

INTRODUCTION TO AIRCRAFT INDUSTRY

(Aeronautical Engineering)

Date : 11 December, 2013

Time : 3 Hours

Max. Marks : 75

Answer ONE question from each Unit

All Questions Carry Equal Marks

All parts of the question must be answered in one place only

Unit - 1

1. a) Describe the characteristics of Wright Flyer which was developed by Wright Brothers. 7M
- b) Explain the various improvements that took place in aircraft industry during the period between World War I and II. 8M
2. a) Give a brief scenario of the growth of Indian aviation industry. 8M
- b) Explain the hierarchical advancements in space exploration right from the birth of Sputnik-I. 7M

Unit – 2

3. a) Give the detailed classification of aircrafts. 7M
- b) What are flight control surfaces? Explain primary and secondary flight control surfaces. 8M
4. a) Mention the different types of tail arrangements of an aircraft and explain their uses. 8M
- b) Draw a neat sketch of an airplane and identify the basic components of it. 7M

Unit - 3

5. a) Give a brief classification of aircraft systems. 6M
- b) What is a control system? Explain engine control system. 9M
6. a) Explain the need for controlled environment for crew, passengers and equipment in an airplane. 7M
- b) Classify the refrigeration systems used in aircraft. 8M

Unit - 4

7. a) Calculate the standard atmosphere value of temperature (T), pressure (P) and density (ρ) at geopotential altitude of 14Km. 8M
- b) Derive Bernoulli's equation. 7M
8. a) Define stalling of an aircraft. Explain the phenomenon of stalling with a suitable graph. 7M
- b) Define lift and drag. Mention the different types of drag. 8M

Unit - 5

9. a) Explain the different types of flows with respect to mach number. 8M
- b) Derive the equations of motion for an airplane in translational flights. 7M
10. a) With appropriate expression, show that glide angle of an airplane is strictly a function of lift to drag ratio. 8M
- b) Explain the loads acting on an aircraft during pull up and pull down conditions. 7M

--	--	--	--	--	--	--	--	--	--



VARDHAMAN COLLEGE OF ENGINEERING
(AUTONOMOUS)

B. Tech III Semester Regular Examinations, December - 2013

(Regulations: VCE-R11)

STRENGTH OF MATERIALS-I

(Civil Engineering)

Date : 11 December, 2013

Time : 3 Hours

Max. Marks : 75

Answer ONE question from each Unit

All Questions Carry Equal Marks

All parts of the question must be answered in one place only

Unit - 1

1. a) Derive an expression between modulus of elasticity and modulus of rigidity. 6M
- b) A compound bar consists of a circular rod of steel of diameter 20 mm rigidly fitted into a copper tube of internal diameter 20 mm and thickness of 5mm. If the bar is subjected to a load of 100kN, find the stresses developed in the two materials. 9M
2. a) Distinguish between lateral strain and longitudinal strain, nominal stress and true stress. 6M
- b) A steel bar of 20 mm diameter and 1m long is freely suspended from a roof and is provided with a collar at other end. If the modulus of elasticity is $2 \times 10^5 \text{ N/mm}^2$ and maximum permissible stress is 300 N/mm^2 , find
 - i. The maximum load which can fall from a height of 50 mm on the collar.
 - ii. The maximum height from which a 600 N load can fall on the collar.

Unit - 2

3. a) Derive the relationship between loading, Shear force & Bending moment. 5M
- b) Draw shear force and bending moment for the beam shown in fig.1 10M

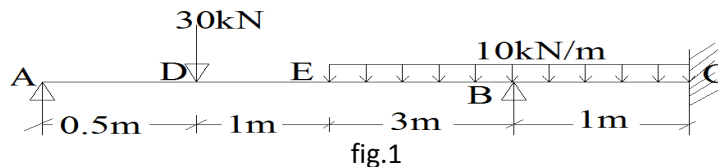

4. a) Define with sketches types of loading and supports. 5M
- b) Draw shear force and bending moment for the cantilever beam carrying UDL of $W \text{ KN/m}$ over the whole span 'L'm. 10M

Unit - 3

5. a) Distinguish between thin and thick cylinders. Explain the modes of failure due to shear with sketches 5M
- b) A cylindrical pressure vessel of 1metre internal diameter and 1.5 m long is subjected to an internal pressure p . Thickness of the cylinder wall is 15 mm. Taking allowable stress for cylinder material as 90 Mpa determine
 - i. Magnitude of maximum pressure p
 - ii. Change in dimensions. Take $E = 200 \text{ Gpa}$ $\nu = 0.3$
6. a) A cylindrical shell is 3m long and is having 1m internal diameter and 15 mm thickness. Calculate the maximum intensity of shear stress induced also the changes in the dimensions of the shell. If it is subjected to an internal fluid pressure of 1.5 N/mm^2 . 7M
- b) A thick cylinder of internal diameter 160 mm is subjected to an internal fluid pressure of 40 N/mm^2 . If the allowable stress in the material is 120 N/mm^2 find the thickness required. 8M

Unit - 4

7. a) Explain theory of simple bending and derive an expression for bending stress. 5M
 b) A Timber beam of rectangular section is to support a 2 tonnes UDL over a span of 3.6m. If the depth of the section is to be twice the breadth and the stress in timber is not to exceed 70kg/cm^2 , find the dimensions of the cross section. How can you modify the cross section of the beam, if it were to carry a concentrated load placed at the centre with the same ratio of breadth to depth? 10M
8. a) Derive an expression for the shearing stress distribution over a Rectangular section. 5M
 b) A steel section shown in fig.2 is subjected to a shear force of 10Tonnes. Determine the shear stress at the important points and sketch the shear distribution diagram. 10M

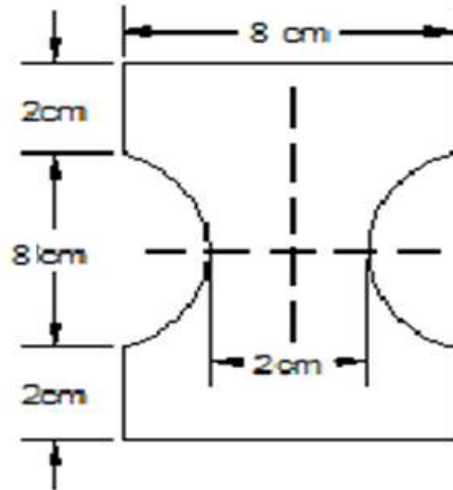

fig.2

Unit - 5

9. a) Derive the relation between slope, deflection and radius of curvature. 5M
 b) A horizontal beam AB is freely supported at A and B, 8m apart, and carries a UDL of 15KN/m . A clockwise moment of 160KN-m is applied to the beam at a point C, 3m from the left hand support A. Calculate the slope of the beam, at C, if $EI=40\text{MN-m}^2$. 10M
10. a) State the Two Mohr's theorems to relate slope and deflection. 5M
 b) A beam of length 5m and of uniform rectangular section is supported at its end and carries UDL over the entire span. Calculate the depth of the section if the maximum permissible bending stress is 8N/mm^2 and central deflection is not to exceed 10mm. 10M

**VARDHAMAN COLLEGE OF ENGINEERING**
(AUTONOMOUS)

B. Tech III Semester Regular Examinations, December - 2013

(Regulations: VCE-R11)

MANAGERIAL ECONOMICS AND FINANCIAL ANALYSIS(Common to Computer Science and Engineering, Information Technology,
Electrical and Electronics Engineering, Aeronautical Engineering & Civil Engineering)

Date : 13 December, 2013

Time : 3 Hours

Max. Marks : 75

Answer ONE question from each Unit**All Questions Carry Equal Marks****All parts of the question must be answered in one place only****Unit – 1**

1. a) Define Managerial Economics. Explain its significance. 8M
b) Discuss the nature and scope of Managerial Economics. What are the other related disciplines? 7M
2. What is the need of demand forecasting? Discuss various statistical methods of demand forecasting. 15M

Unit – 2

3. a) How can isocosts and isoquants be used in economic analysis? Explain. 7M
b) Find the BEP of production in terms of unit and in terms of value if the price of the product is Rs 250 per unit; variable cost is Rs 150 per unit and the fixed cost is Rs. 1,50,000. 8M
4. a) What are the differences between internal and external economies of scale? 8M
b) What Are the Limitations of Break Even Analysis? 7M

Unit – 3

5. a) Monopolistic Competition is a blend of perfect competition and monopoly. Discuss. How is price-output determined under monopolistic competition? 8M
b) What would be your response to the statement, "Profit maximization is the only legitimate pricing objective for the firm"? Elaborate. 7M
6. What are the Types of pricing strategies? Explain with suitable examples. 15M

Unit – 4

7. What is sole trade form or business organization? Discuss its advantages and limitations. 15M
8. ABC Co. Ltd. Is proposing to mechanize their operations. Two proposals A and B in the form of quotations have been received from two different vendors. The proposal in each case Rs. 5,00,000/- a discount factor of 14% is used to compare the proposals cash flow after tax are likely to be as under 15M

Cash flows after Tax (CFAT) in Rs.		
Year	Proposal – A	Proposal – B
1	1,50,000	50,000
2	20,000	1,50,000
3	2,50,000	2,00,000
4	1,50,000	3,00,000
5	1,00,000	2,00,000

Which one do you recommend under Net Present Value method?

Unit – 5

9. a) List and explain profitability ratio's with examples. 8M
 b) Journalize the following transactions in the books of Mr. Ganesh 7M

Date	Particulars	Amount in Rs.
01.01.2005	Mr. Ganesh commenced his business	50,000
03.01.2005	Bought goods for cash	25,000
04.01.2005	Sold goods for cash	20,000
06.01.2005	Deposited into Dena bank	25,000
10.01.2005	Returned goods to Krishna	500
15.01.2005	Purchased machinery from HMT Ltd	5,000
25.01.2005	Advance paid to Mr. Govind as loan	2,000
28.01.2005	Withdrew cash for personal use from business	1,500

Each journal entry with exact debit and credit entries along with narration.

10. From the following trial balance taken from the books of Mohan, prepare trading and profit and loss account for the year ended 31st March 1996 and balance sheet as on that date. 15M

Debit Balances	Rs.	Credit Balances	Rs.
Purchases	9,600	Capital	12,000
Bad debts	400	Sales	20,025
Wages	1,250	Purchase returns	575
Salaries	1,775	Reserve for bad debts	650
Sales returns	325	Discount	500
Traveling expenses	275	Creditors	5,000
Administration expenses	325	Bills payable	1,250
Trade expense	675	Bank over draft	2,000
Interest	1,825		
Building	10,000		
Debtors	6,000		
Furniture	4,000		
Cash	3,000		
stock	2,550		
	42,000		42,000

Additional information:

- i. Stock on 31st march, 1996 was Rs. 7,000
- ii. Depreciate building by 5 % and furniture by 10%
- iii. Increase reserve for bad and doubtful debts by 5% on debtors
- iv. Outstanding expenses were: salaries Rs. 500, wages Rs.250, trade expense Rs.100
- v. Commission earned but not received Rs. 225

--	--	--	--	--	--	--	--	--	--



VARDHAMAN COLLEGE OF ENGINEERING
(AUTONOMOUS)

B. Tech III Semester Regular Examinations, December - 2013
(Regulations: VCE-R11)

PROBABILITY THEORY AND STOCHASTIC PROCESSES
(Electronics and Communication Engineering)

Date : 13 December, 2013

Time : 3 Hours

Max. Marks : 75

Answer ONE question from each Unit

All Questions Carry Equal Marks

All parts of the question must be answered in one place only

Unit – 1

1. a) There are three unbiased coins and one biased coin with head on both sides. A coin is chosen at random and tossed 4 times. If head occurs all the four times, what is the probability that the biased coin has been chosen? 8M

- b) Find the characteristic function of an exponential distribution 7M

$$f(x) = \begin{cases} \alpha e^{-\alpha x}, & x > 0 \\ 0, & \text{otherwise} \end{cases}$$

Hence find the mean and variance

2. a) A missile can be accidentally launched if two relays A and B both have failed. The probabilities of A and B failing are known to be 0.01 and 0.03 respectively. It is also known that B is more likely to fail (probability 0.06) if A failed. 8M
- What is the probability of an accidental missile launch?
 - What is the probability that A will fail if B has failed?
 - Are events "A fails" and "B fails" statistically independent?

- b) A random variable X has a probability density 7M

$$f_X(x) = \begin{cases} \left(\frac{\pi}{16}\right) \cos\left(\frac{\pi x}{g}\right); & -4 \leq x \leq 4 \\ 0 & ; \text{ elsewhere} \end{cases}$$

Find

- Mean value
- its second moment

Unit – 2

3. a) List the properties of the joint distribution function for two random variables X and Y? 6M

- b) Two random variables X and Y have the density function 9M

$$f_{X,Y}(x, y) = \begin{cases} \frac{2}{43}(x + 0.5y)^2 & ; 0 < x < 2 \text{ and } 0 < y < 3 \\ 0 & ; \text{ elsewhere} \end{cases}$$

- Find all the first and second order moments
- Find the covariance
- Are X and Y uncorrelated?

4. a) Given the joint function 8M

$$f_{X,Y}(x,y) = \begin{cases} \frac{(x^2 + y^2)}{8\pi} & ; x^2 + y^2 < b \\ 0 & ; \text{elsewhere} \end{cases}$$

- i. Find a constant so that this is a valid joint density function.
 ii. Find $P\{0.5b < x^2 + y^2 \leq 0.8b\}$.
- b) Two random variables X and Y have means $E[X] = 1$ and $E[Y] = 2$ and, variances $\text{Var}[X] = 4$ and $\text{Var}[Y] = 1$ and a correlation coefficient is 0.4. New random variables W and V are defined by $V = -X + 2Y$ $W = X + 3Y$
 Find i) mean ii) variance iii) correlation coefficient ρ_{VW} of V and W. 7M

Unit – 3

5. a) Explain cross correlation function and prove its properties. 9M
 b) Consider the random process, X (t) given by $X(t) = A\cos(2\pi f_c t + \theta)$, where A and f_c are constants and θ is a random variable that is uniformly distributed over the interval $(-\pi, \pi)$. Determine the auto correlation function of X(t). 6M
6. a) Let two random process X(t) and Y(t) be defined by 7M
 $X(t) = A\cos\omega_0 t + B\sin\omega_0 t$
 $Y(t) = B\cos\omega_0 t - A\sin\omega_0 t$
 Where A and B are random variables assumed to be zero mean and un correlated. Also A and B are assumed to have variance σ^2 . Find the cross correlation function $R_{xy}(\tau)$.
- b) A random process is defined as $X(t) = A \cos(\pi t)$. Where A is a Gaussian random variable with zero mean and variance σ_A^2 . 8M
 i. Find the density functions $X(0)$ and $X(1)$
 ii. Is X(t) stationary in any sense?

Unit - 4

7. a) Given that the process X(t) has an auto correlation $R_{xx}(\tau) = Ae^{-\alpha|\tau|} \cos(\omega_0 \tau)$ where $A, \alpha > 0$ and ω_0 are real constants, find power spectrum of X(t). 8M
 b) Consider a bridge circuit with white noise of spectral density N_0 as input. Find the spectral density of the output for the following fig.1 7M

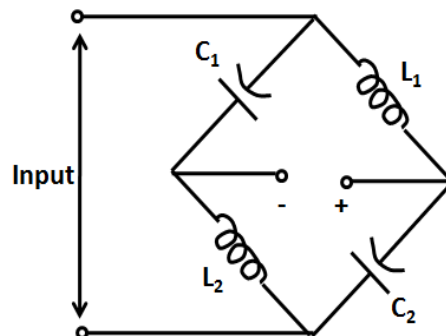

fig.1

8. a) Derive the relation between cross power density spectrum and cross correlation function of a random process. 8M
- b) Define cross power spectral density of two continuous time random process $X(t)$ and $Y(t)$. Prove that 7M
- i. $S_{XY}(w) = S_{YX}(-w)$
 - ii. $S_{XY}(-w) = S_{XY}^*(w)$
 - iii. If $X(t)$ and $Y(t)$ are orthogonal then $S_{XY}(w) = 0$

Unit – 5

9. a) Obtain an expression to find Noise figure of a multistage amplifier with a neat figure. 8M
- b) Develop a mathematical model of narrow band Noise and discuss its related properties. 7M
10. a) Define in-phase component and quadrature-phase component. Show that a narrow-band noise process can be expressed as in-phase and quadrature components of it. 8M
- b) Define average noise figure and average noise temperature. Derive mathematical expressions for both. 7M

--	--	--	--	--	--	--	--	--	--



VARDHAMAN COLLEGE OF ENGINEERING
(AUTONOMOUS)

B. Tech III Semester Regular Examinations, December - 2013

(Regulations: VCE-R11)

METALLURGY & MATERIAL SCIENCE

(Mechanical Engineering)

Date : 13 December, 2013

Time : 3 Hours

Max. Marks : 75

Answer ONE question from each Unit

All Questions Carry Equal Marks

All parts of the question must be answered in one place only

Unit – 1

1. a) Explain the term unit cell. List all the Bravais lattices in decreasing order of symmetry. 7M
- b) Give a test method for determining grain size of metals. Write the Hall-Petch relation and sketch a typical plot of yield strength Vs grain size. 8M
2. a) Enumerate on the need for alloying. State Hume Rothery rules for substitutional solid solution. 7M
- b) What is solid solution? Discuss various types of solid solution. 8M

Unit – 2

3. a) A binary phase diagram is expected to be of isomorphous type. Describe all the steps to construct the phase diagram. Label all areas, lines and points in the phase diagram. 7M
- b) Explain the following with an example for each: 8M
 - i. Eutectic reaction
 - ii. Peritectic reaction
 - iii. Eutectoid reaction
 - iv. Peritectoid reaction
4. a) Draw Iron-Carbon equilibrium diagram and list all the phase reactions. 7M
- b) Lead melts at 324⁰C and tin melts at 280⁰C. They form a eutectic containing 62% tin at 180⁰C. The maximum solubility of tin in lead at this temperature is 19% of lead in tin is 3%. Assuming the solubility of each at room temperature is 1%. Draw the equilibrium diagram labeling all lines, points and areas. For an alloy containing 40% tin, give the initial temperature of solidification, final temperature of solidification and percentage of eutectic phase present at room temperature. 8M

Unit – 3

5. a) Explain the effect of alloying elements on Fe-Fe₃C system. 6M
- b) Compare gray cast iron and SG cast iron with respect to composition, structure, properties and uses. 9M
6. a) With a neat sketch explain Time – Temperature – Transformation diagram for steel with eutectoid composition. Explain the term critical cooling rate. 7M
- b) Enumerate on surface hardening methods highlighting the process principle, process parameters and merits of each of the process. 8M

Unit – 4

7. a) Enumerate on different types of Titanium alloys – highlight the general characteristics and applications. 7M
- b) Describe the composition, properties and applications of the following 8M
 - i. Beryllium bronzes
 - ii. Phosphor bronzes

:: 2 ::

8. a) Explain why ceramics are typically processed as powders. How this is similar to or different from the processing of metals. 8M
- b) Write a short note on Refractories. List out the various industrial applications of the refractory materials. 7M

Unit – 5

9. a) Define a composite material and give an example each for natural and synthetic composite material. 7M
- b) Explain Hand lay-up method for making Glass Fiber Reinforced Plastic. Highlight the process steps and applications. 8M
10. a) Enumerate on Metal Matrix composites highlighting methods of manufacturing and applications. 7M
- b) Enumerate on C – C composite plastic – the general characteristics and applications. 8M