

CIVIL ENGINEERING – PAPER - I

Time : 3 Hours

Max. Marks : 200

Note : 1. Attempt any five (05) questions. All questions carry equal marks.
 2. Indian Standard Code of Practice for Prestress Concrete IS 1343-1980 is required

1. Determine the ultimate moment of resistance for the T-beam section of effective width of 850 mm shown below (Fig. 1). Assume M20 grade concrete and Fe 250 grade steel. (40)

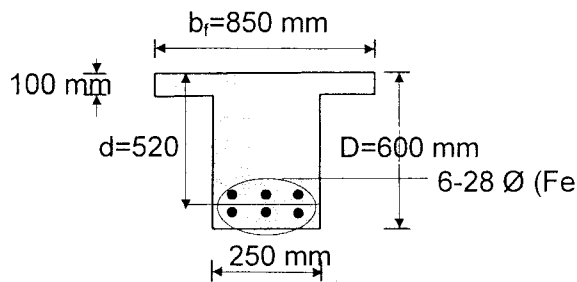

Fig. 1

2. Design shear-reinforcement for the doubly reinforced beam shown in Fig. 2. The beam is simply supported with a total centre-to-centre span of 6.0 m. Use 8mm ϕ vertical stirrups made of Fe 250 steel. The shear at the bar-cutoff point (860 mm from centre of support) also needs to be checked. The concrete is of M25 and flexural steel of Fe 415. (40)

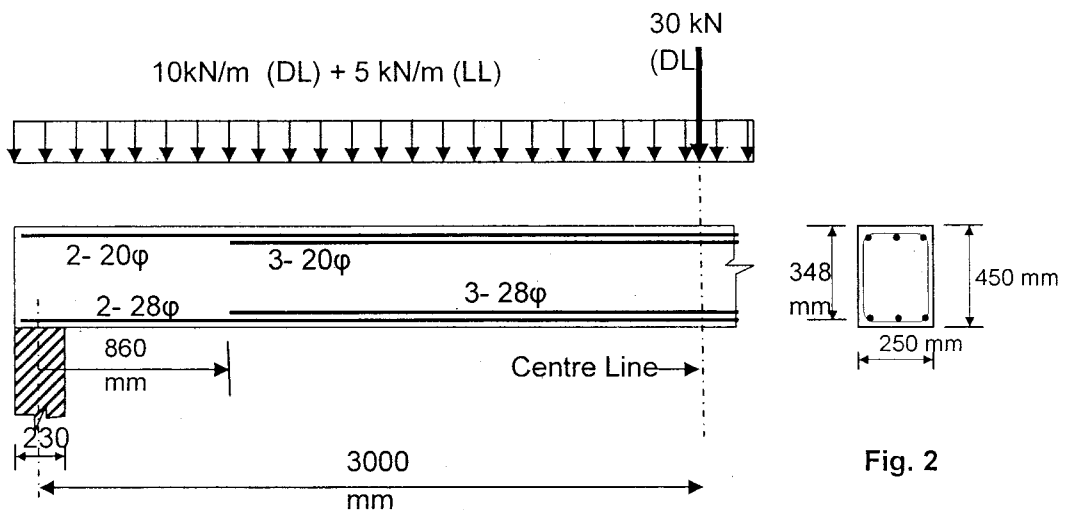

Fig. 2

3. A pretensioned beam 200 mm wide and 300 mm deep is prestressed by 10 wires of 7 mm diameter initially stressed to 1200 N/mm^2 , with their centroids located 100 mm from the soffit. Find the maximum stress in concrete immediately after transfer, allowing only for elastic shortening of concrete. If the concrete undergoes further shortening due to creep and shrinkage while there is relaxation of 5 % steel stress, estimate the percentage loss of stress in the wires, using the IS code (IS 1343-1980) regulations, and the following data (40)

$$E_s = 210 \text{ kN/mm}^2$$

$$E_c = 5700 (f_{cu})^{1/2}$$

$$f_{cu} = 42 \text{ N/mm}^2$$

$$\text{Creep coefficient } \phi = 1.6$$

$$\text{Total residual shrinkage strain} = 300\text{E-}6$$

4. Generate the stiffness matrix for the beam with respect the coordinates shown in the Fig.3 (40)

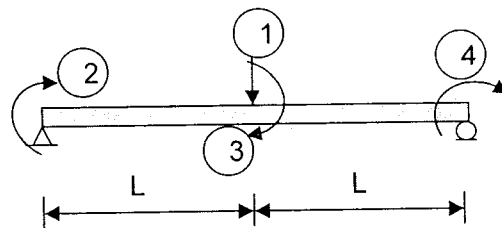

Fig. 3

5. Find the collapse load for the portal frame shown in Fig. 4 (40)

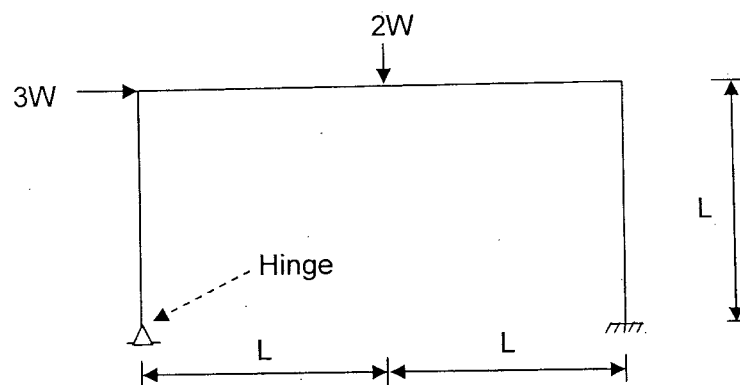

Fig. 4

6. A 300 I.S.F 8 mm is used as a tension member in a lattice girder. It is connected to a 12 mm gusset plate by 18 mm ϕ hand-driven rivets. The yield stress of steel is 250 N/mm^2 . Calculate the maximum force that the member can carry, if (40)
- Chain riveting is done as shown in Fig. 5a
 - Zig-zag riveting is done as shown in Fig. 5b

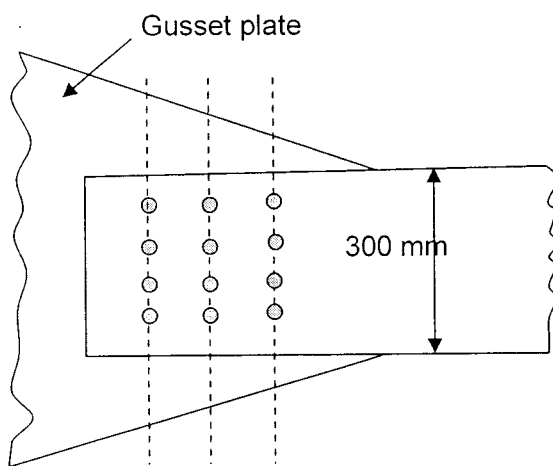

Fig. 5b) Zig-zag riveting

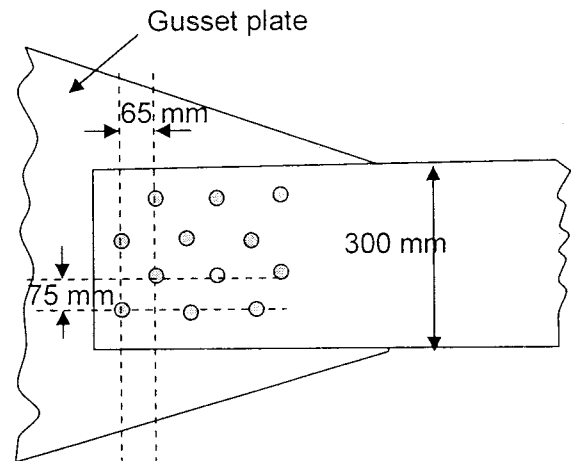

Fig. 5a) Chain riveting

7. A rectangular block $250 \text{ mm} \times 100 \text{ mm} \times 80 \text{ mm}$ is subjected to axial load as follows: (40)
- 480 kN tensile in the direction of its length
 - 900 kN tensile on the $250 \text{ mm} \times 80 \text{ mm}$ faces
 - 1000 kN compressive on the $250 \text{ mm} \times 100 \text{ mm}$ faces
- Assuming Poissons's ratio as 0.25, and Young's modulus to be $2 \times 10^5 \text{ N/mm}^2$, evaluate the following.

- Volumetric strain
- The change in volume of the block due to the application of the above load
- Modulus of rigidity and bulk modulus for the material